

# SEAHAWK DECO

-Aluminum Profile Catalogue-

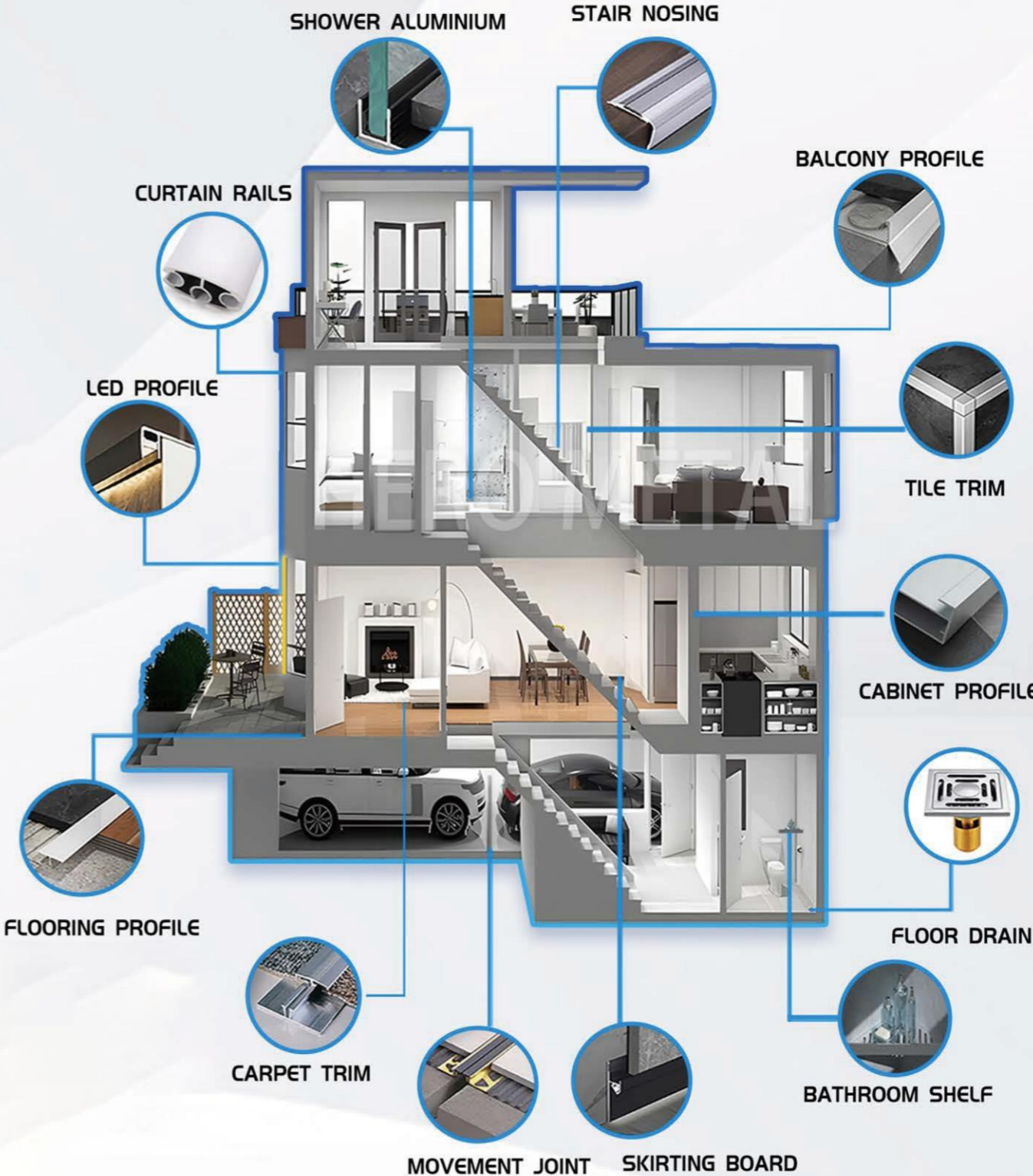

# PRODUCT COLOR CARD

## STAINLESS STEEL



## VARNISHED ALUMINIUM STONE LINE



## ALUMINIUM



## VARNISHED ALUMINIUM



## VARNISHED ALU.(embossed)



# PRODUCT COLOR CARD



## MARBLED ON DEMAND



## WOOD



## PUNCHING HOLE STYLE

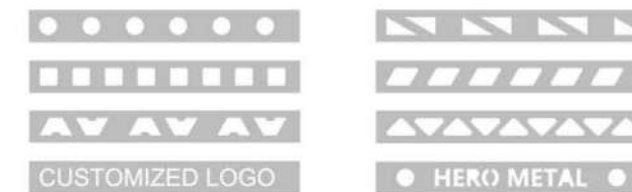

ROUND EDGE TRIM



ROUND EDGE TRIM

15

Round Edge Trim

ROUND EDGE TRIM is a specialized tile edging profile with a distinctive "R" shape, designed to protect and enhance tiled edges. Its advantages lie in providing a seamless transition between different surfaces, preventing edge damage and offering a sleek, finished look. Widely used in bathrooms and kitchens, the R-shaped trim is particularly effective in high-moisture environments, ensuring both aesthetic appeal and long-lasting durability.

ACCESSORIES



Round Edge Trim

EXAMPLES AND INSTRUCTIONS FOR LAYING METHODS

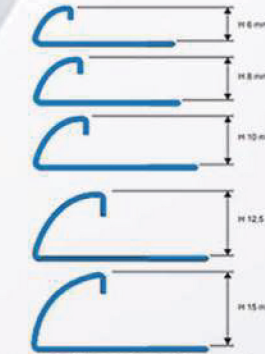
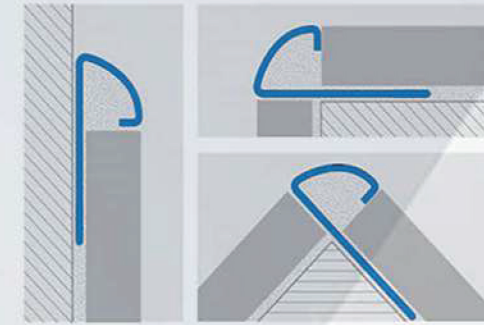

CODE	H MM	KG/M
HM-R-047	6	0.120
HM-R-046	8	0.122
HM-R-048	10	0.129
HM-R-049	11	0.132
HM-R-050	12.5	0.140
HM-R-051	15	0.144

Installation procedure



1. Choose ROUND EDGE TRIM according to the thickness of the tile and in the desired finish. 2. Cut ROUND EDGE TRIM to the desired length and apply the adhesive on the support where the profile will be laid. 3. Press the anchoring flange of ROUND SHAPE TRIM into the adhesive. 4. Lay the tiles, aligning them with the profile and leaving a 2 mm joint. Remove immediately all the remains of adhesive from the surface of the profile. 5. Fill the joints between the profile and the tile with plaster in order to avoid water stagnation. Remove immediately all the remains of plaster from the surface of the profile.

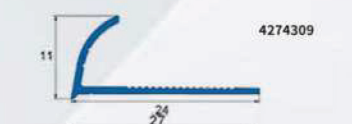

CODE	H MM	KG/M
4274308	9.8	0.087
4274300	12.5	0.106



CODE	H MM	KG/M
HM-R-008	10	0.10
HM-R-084	12	0.105

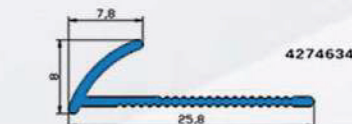

1. Choose ROUND EDGE TRIM according to the thickness of the tile and in the desired finish. 2. Cut ROUND EDGE TRIM to the desired length and apply the adhesive on the support where the profile will be laid. 3. Press the anchoring flange of ROUND SHAPE TRIM into the adhesive. 4. Lay the tiles, aligning them with the profile and leaving a 2 mm joint. Remove immediately all the remains of adhesive from the surface of the profile. 5. Fill the joints between the profile and the tile with plaster in order to avoid water stagnation. Remove immediately all the remains of plaster from the surface of the profile.

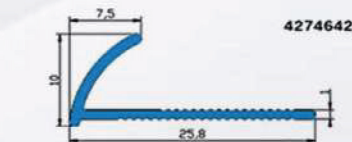

CODE	H MM	KG/M
4274634	6	0.087
4274642	8	0.092
4274643	10	0.098
4274672	12.2	0.103

EXAMPLES AND INSTRUCTIONS FOR LAYING METHODS

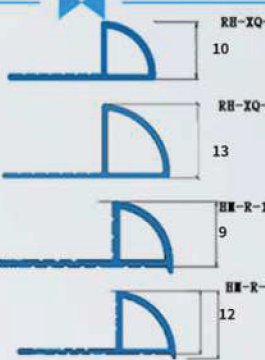
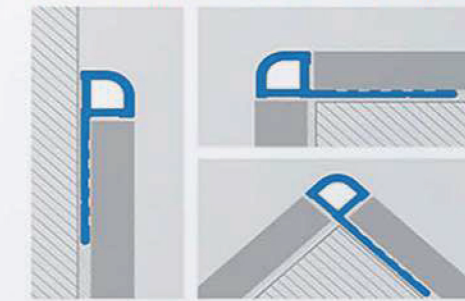

CODE	H MM	KG/M
HM-R-139	9	0.131
RH-XQ-15	10	0.125
HM-R-140	12	0.174
RH-XQ-16	13	0.155

EXAMPLES AND INSTRUCTIONS FOR LAYING METHODS

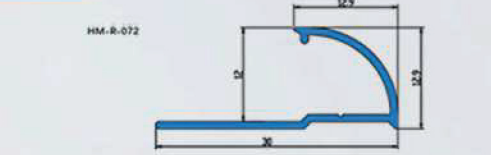
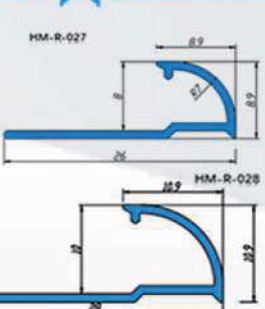
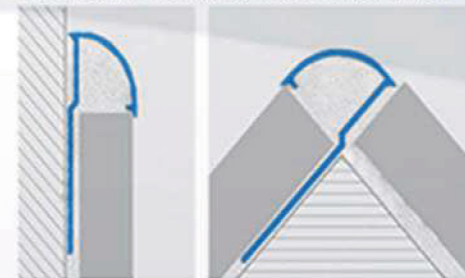

CODE	H MM	KG/M
HM-R-027	8	0.10
HM-R-028	10	0.11
HM-R-072	12	0.124

16

# Round Edge Trim

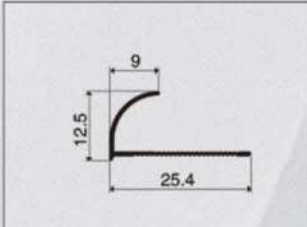
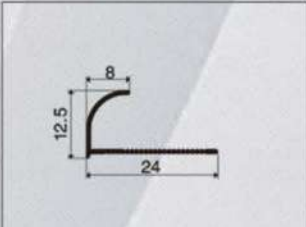
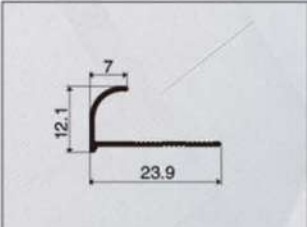
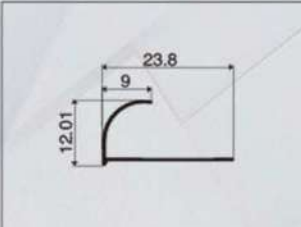
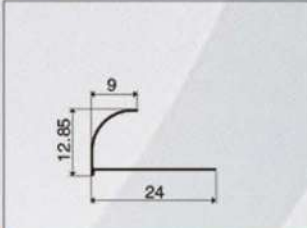
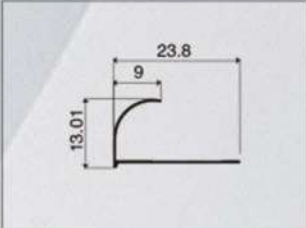
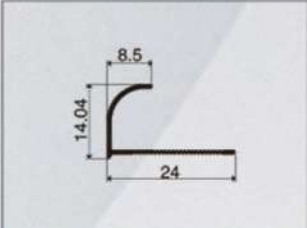
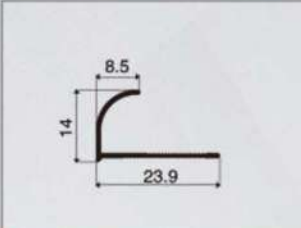
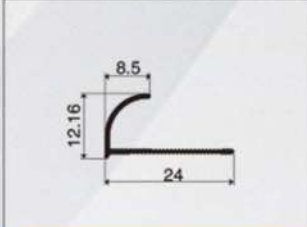
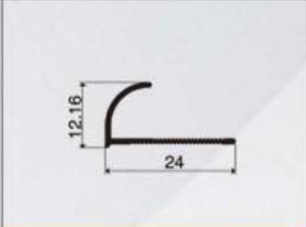
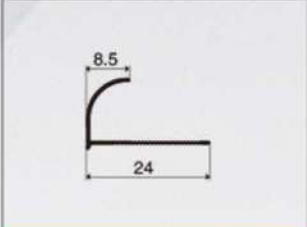
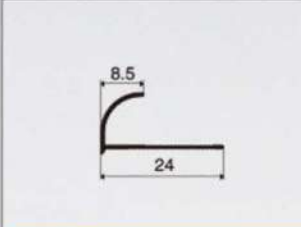
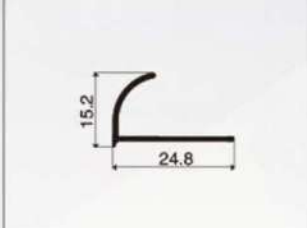
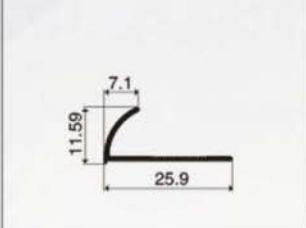
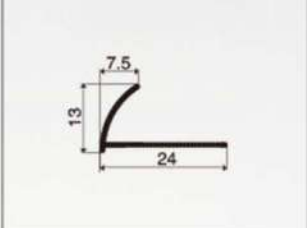
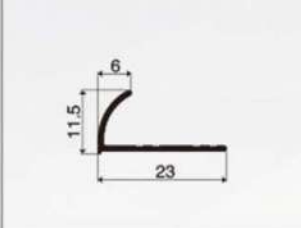
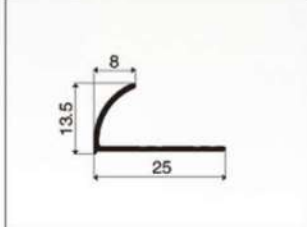
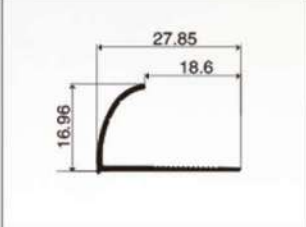
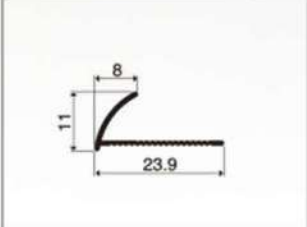
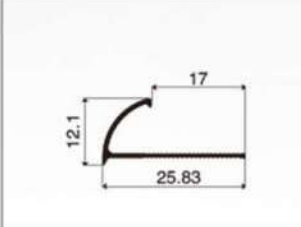
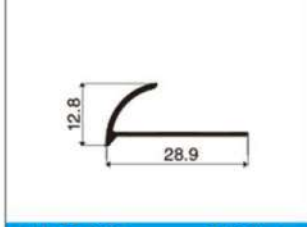
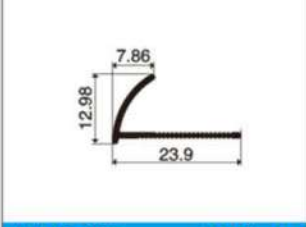
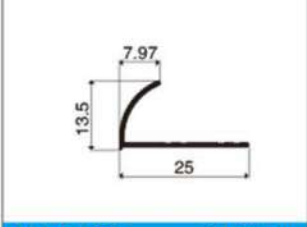
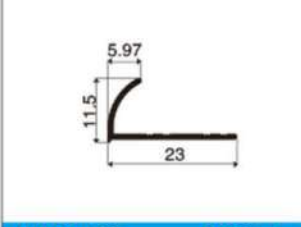
			
HM-R-112 0.078kg/m	HM-R-113 0.083kg/m	HM-R-115 0.090kg/m	HM-R-124 0.059kg/m
			
HM-R-129 0.044kg/m	HM-R-131 0.049kg/m	HM-R-135 0.087kg/m	HM-R-135 0.087kg/m
			
HM-R-136 0.088kg/m	HM-R-136 0.095kg/m	HM-R-137 0.078kg/m	HM-R-138 0.078kg/m
			
HM-R-007 0.115kg/m	HM-R-008 0.100kg/m	HM-R-016 0.090kg/m	HM-R-019 0.093kg/m
			
HM-R-020 0.107kg/m	HM-R-023 0.116kg/m	HM-R-024 0.079kg/m	HM-R-046 0.084kg/m
			
HM-R-052 0.106kg/m	HM-R-057 0.103kg/m	HM-R-058 0.101kg/m	HM-R-059 0.088kg/m



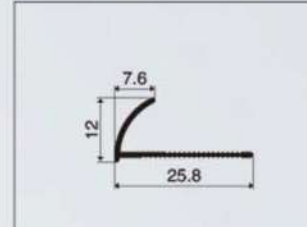
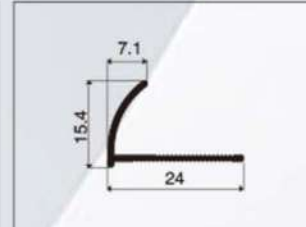
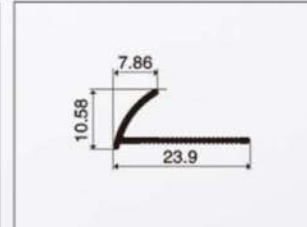
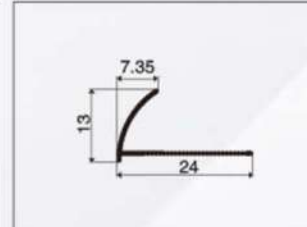
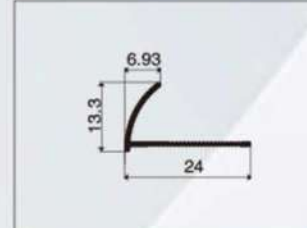
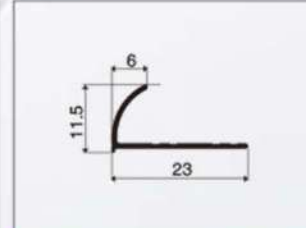
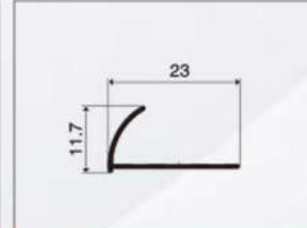
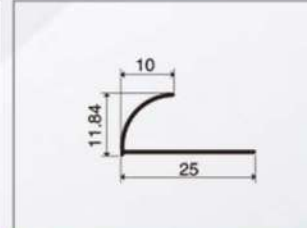
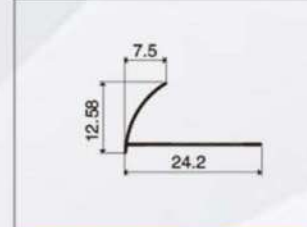
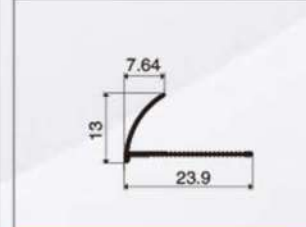
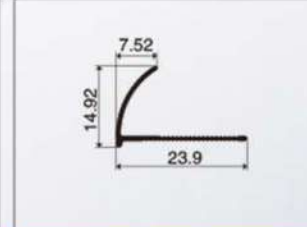
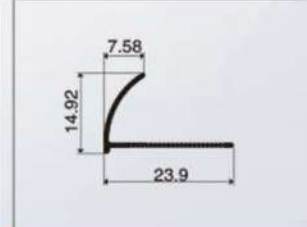
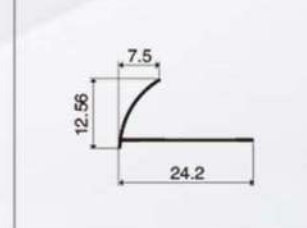
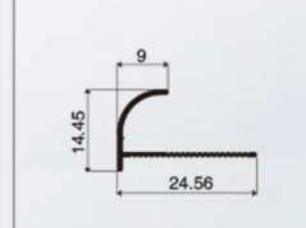
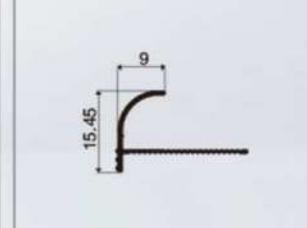
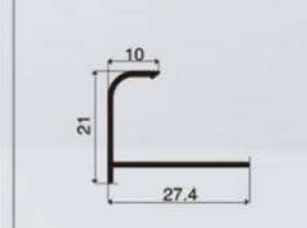
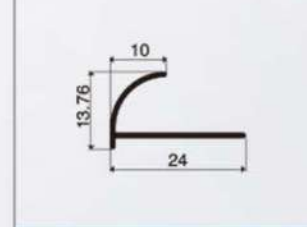
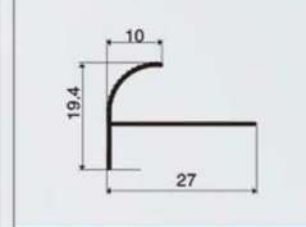
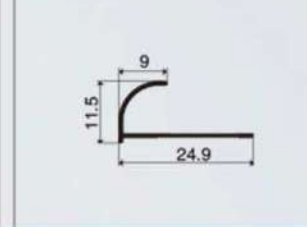
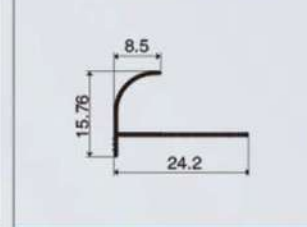
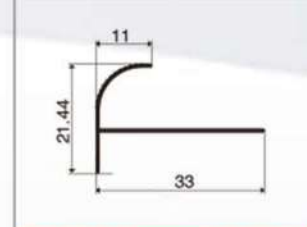
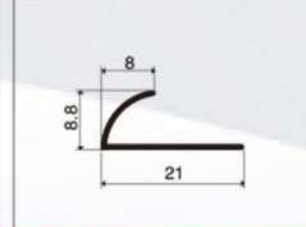
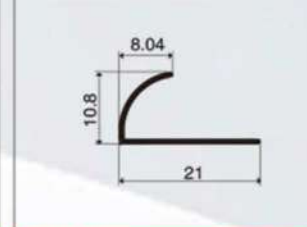
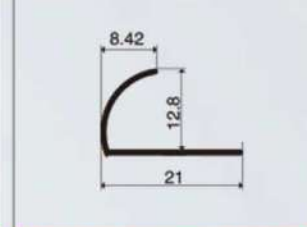

17

# Round Edge Trim

			
HM-R-060 0.092kg/m	HM-R-062 0.116kg/m	HM-R-064 0.096kg/m	HM-R-066 0.074kg/m
			
HM-R-067 0.094kg/m	HM-R-095 0.075kg/m	HM-R-101 0.075kg/m	HM-R-107 0.073
			
HM-R-110 0.046kg/m	HM-R-123 0.082kg/m	HM-R-127 0.082kg/m	HM-R-128 0.089kg/m
			
HM-R-134 0.049kg/m	HM-R-001 0.092kg/m	HM-R-002 0.098kg/m	HM-R-030 0.146kg/m
			
HM-R-073 0.100kg/m	HM-R-092 0.099kg/m	HM-R-098 0.080kg/m	HM-R-109 0.081kg/m
			
HM-R-120 0.117kg/m	HM-R-031 0.071kg/m	HM-R-032 0.075kg/m	HM-R-033 0.080kg/m

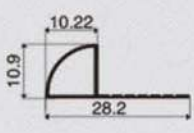
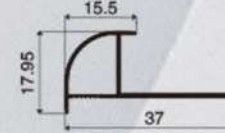
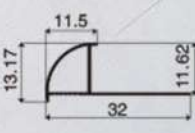
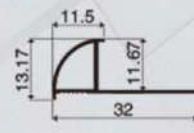
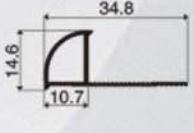
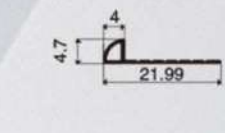
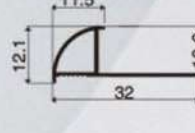
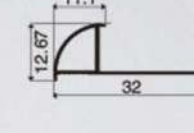
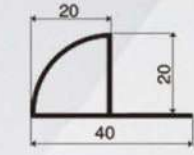
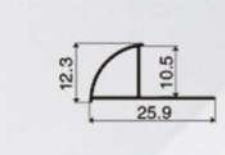
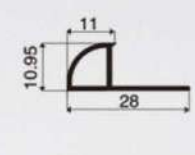
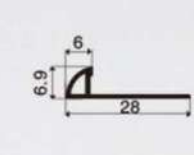
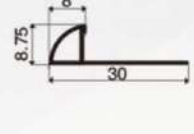
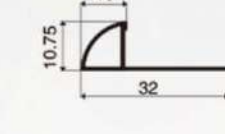
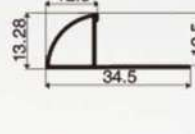
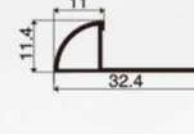
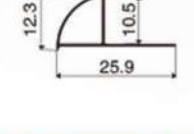
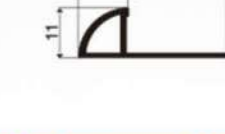
18

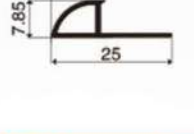
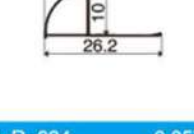
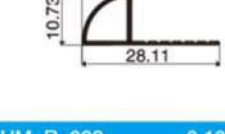
# Round Edge Trim

			
HM-R-004 0.090kg/m	HM-R-005 0.080kg/m	HM-R-022 0.090kg/m	HM-R-022-2 0.108kg/m
			
HM-R-047 0.217kg/m	HM-R-053 0.054kg/m	HM-R-055 0.103kg/m	HM-R-055-2 0.108kg/m
			
HM-R-063 0.244kg/m	HM-R-068 0.070kg/m	HM-R-075 0.140kg/m	HM-R-078 0.094kg/m
			
HM-R-079 0.100kg/m	HM-R-080 0.116kg/m	HM-R-081 0.138kg/m	HM-R-085 0.130kg/m
			
HM-R-086 0.063kg/m	HM-R-088 0.174kg/m	HM-R-089 0.194kg/m	HM-R-093 0.107kg/m
			
HM-R-094 0.057kg/m	HM-R-099 0.108kg/m	HM-R-102 0.131kg/m	HM-R-103 0.174kg/m

# Round Edge Trim

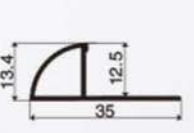
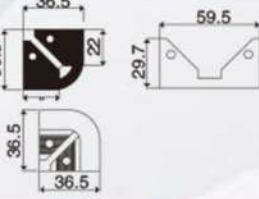
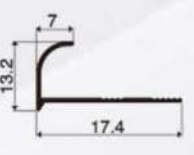
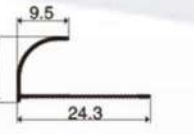



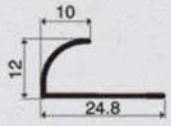
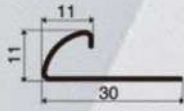
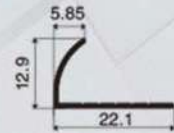
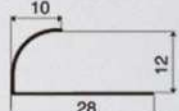
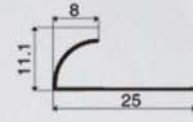
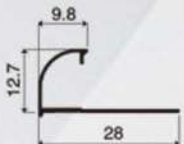
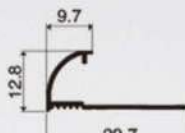
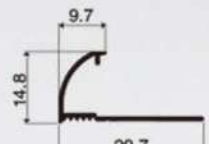
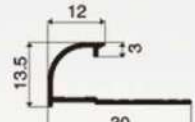
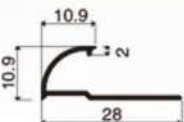
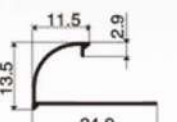
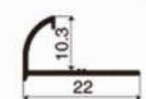
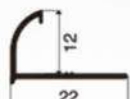
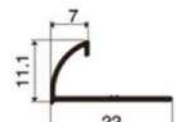
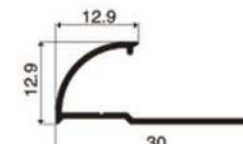

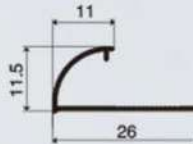

			
HM-R-121 0.138kg/m	HM-R-125 0.051kg/m	DRA125-A 0.163kg/m	HM-DRA125 0.163kg/m
			
HM-R-126 0.118kg/m	HM-R-139 0.131kg/m	HM-R-140 0.174kg/m	HM-R-009 0.000kg/m
			
HM-R-010-011 0.000kg/m	HM-R-025 0.090kg/m	HM-R-026 0.100kg/m	HM-R-040 0.075kg/m
			
HM-R-043 0.075kg/m	HM-R-044 0.081kg/m	HM-R-051 0.100kg/m	HM-R-061 0.098kg/m
			
HM-R-071 0.060kg/m	HM-R-084 0.105kg/m	HM-R-087 0.047kg/m	HM-R-096 0.070kg/m
			
HM-R-097 0.066kg/m	HM-R-100 0.049kg/m	HM-R-104 0.050kg/m	HM-R-105 0.087kg/m

## Round Edge Trim

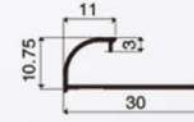
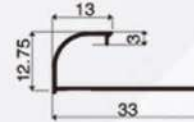
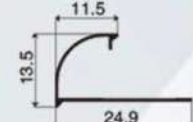
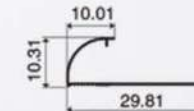
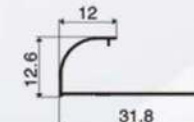
 HM-R-037 0.105kg/m	 HM-R-048 0.129kg/m	 HM-R-076 0.081kg/m	 HM-R-077 0.086kg/m
 HM-R-090 0.056kg/m	 HM-R-091 0.068kg/m	 HM-R-114 0.143kg/m	 HM-R-117 0.052kg/m
 HM-R-003 0.090kg/m	 HM-R-006 0.087kg/m	 HM-R-010 0.120kg/m	 HM-R-011 0.124kg/m
 HM-R-012 0.092kg/m	 HM-R-017 0.122kg/m	 HM-R-018 0.138kg/m	 HM-R-027 0.098kg/m
 HM-R-028 0.110kg/m	 HM-R-038 0.076kg/m	 HM-R-041 0.093kg/m	 HM-R-042 0.098kg/m
 HM-R-045 0.072kg/m	 HM-R-069 0.087kg/m	 HM-R-072 0.123kg/m	 HM-R-074 0.093kg/m

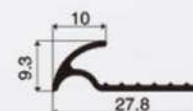
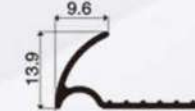
21

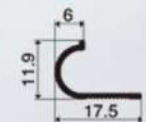
## Round Edge Trim

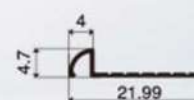
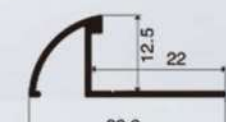
 HM-R-082 0.095kg/m	 HM-R-083 0.100kg/m	 HM-R-118 0.103kg/m	 HM-R-119 0.117kg/m
 HM-R-122 0.064kg/m	 HM-R-132 0.060kg/m	 HM-R-133 0.067kg/m	 HM-R-013 0.148kg/m
 HM-R-034 0.124kg/m	 HM-R-035 0.132kg/m	 HM-R-036 0.132kg/m	 HM-R-070 0.083kg/m
 HM-R-130 0.138kg/m	 HM-R-054 0.050kg/m	 HM-R-106 0.154kg/m	

22

## STRAIGHT EDGE TRIM



23

## STRAIGHT EDGE TRIM

STRAIGHT EDGE TRIM is a versatile edging profile used mainly in tile installations. It provides a protective and aesthetic edge finish, enhancing the longevity of tiled surfaces. Its advantages include ease of installation, durability and the ability to seamlessly blend with various tile designs, making it an ideal choice for both residential and commercial projects.

### Application



## STRAIGHT EDGE TRIM

## STRAIGHT EDGE TRIM

### EXEMPLES OF LAYING

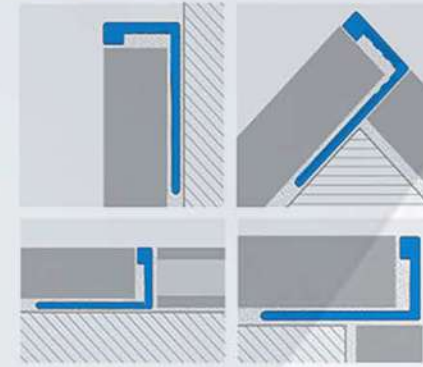

### Installation procedure



1. Choose the STRAIGHT EDGE TRIM with the same height as the thickness of the covering. 2. Apply the adhesive onto the area of application of the profile. 3. Lay and align the profile pressing the perforated flange into the adhesive. 4. Lay the tiles, aligning them so that the top edge of the profile is "flush" with the tile. 5. Use the adhesive to seal any empty interstices.

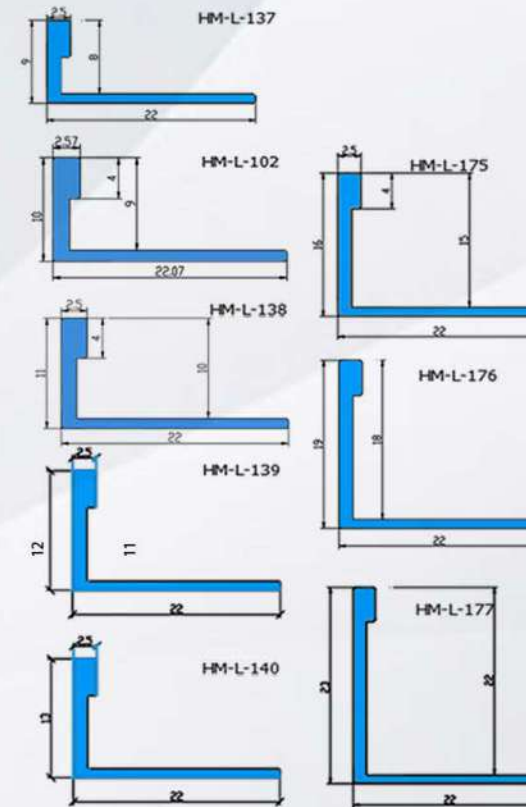

CODE	HIGHT/MM	WEIGHT KG/M
HM-L-137	8	0.103
HM-L-102	9	0.114
HM-L-138	10	0.110
HM-L-139	11	0.115
HM-L-252	11	0.077
HM-L-175	15	0.131
HM-L-176	18	0.144
HM-L-177	22	0.160

24

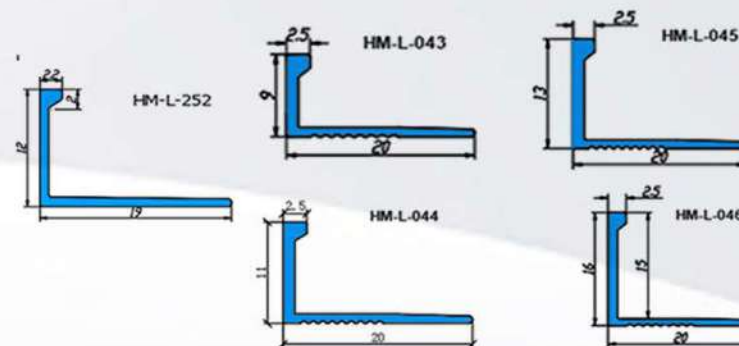

CODE	HIGHT/MM	WEIGHT KG/M
HM-L-043	8	0.083
HM-L-044	10	0.090
HM-L-252	11	0.077
HM-L-045	12	0.096
HM-L-046	15	0.107



# STRAIGHT EDGE TRIM

EXEMPLES OF LAYING

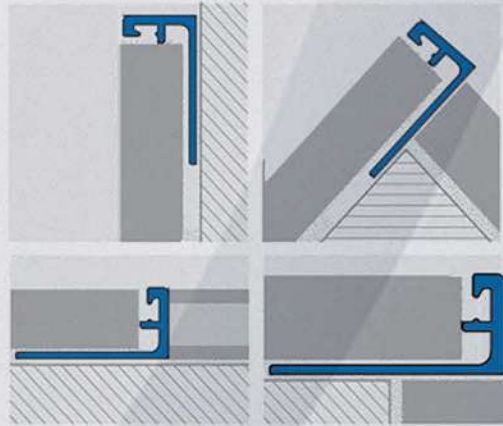

Application

## Installation procedure

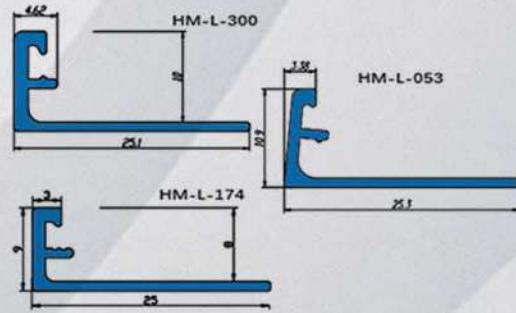

CODE	HIGHT/MM	WEIGHT KG/M
HM-L-174	8	0.112
HM-L-053	10	0.118
HM-L-300	10	0.125

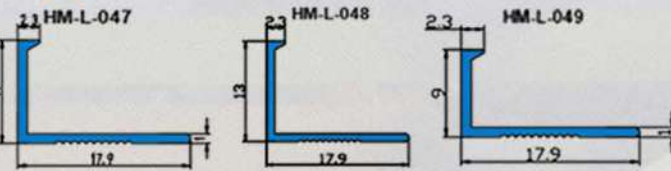

CODE	HIGHT/MM	WEIGHT KG/M
HM-L-049	8	0.070
HM-L-047	10	0.075
HM-L-048	12	0.080

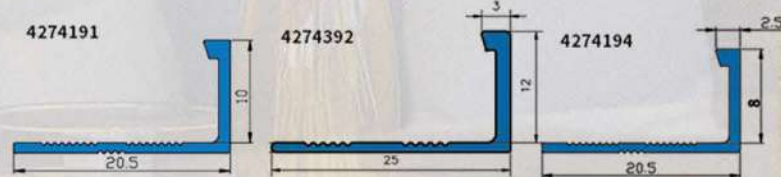

CODE	HIGHT/MM	WEIGHT KG/M
4274194	8	0.082
4274191	10	0.088
4274192	12	0.120



# Straight Edge Trim

# STRAIGHT EDGE TRIM

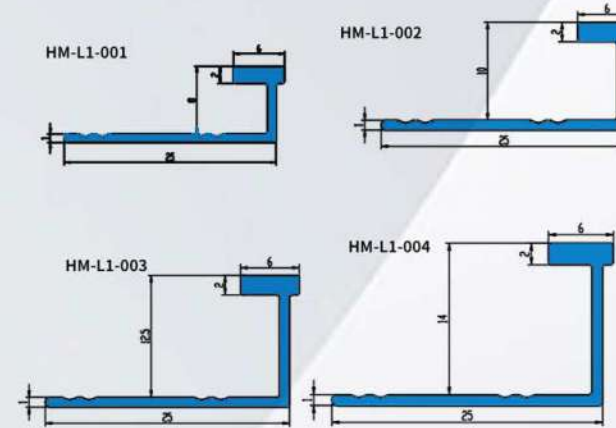

CODE	HIGHT/MM	WEIGHT KG/M
HM-L1-001	8	0.114
HM-L1-002	10	0.119
HM-L1-003	12.5	0.126
HM-L1-004	14	0.130

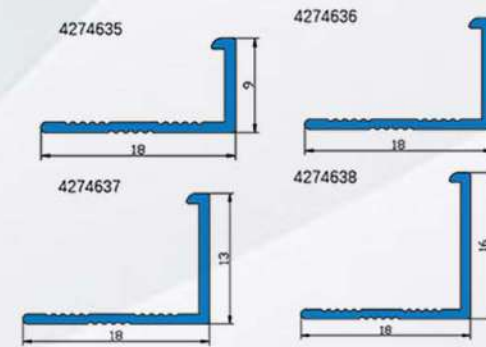

CODE	HIGHT/MM	WEIGHT KG/M
4274635	8	0.070
4274636	10	0.075
4274637	12	0.081
4274638	15	0.089

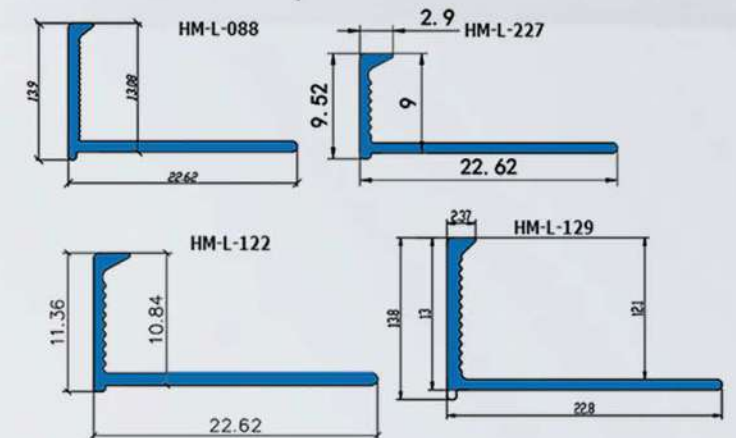

CODE	HIGHT/MM	WEIGHT KG/M
HM-L-227	8	0.085
HM-L-222	10	0.092
HM-L-129	12	0.097
HM-L-088	13	0.104

# STRAIGHT EDGE TRIM

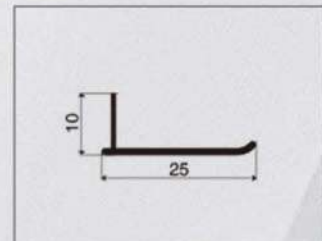
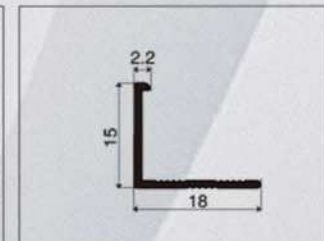
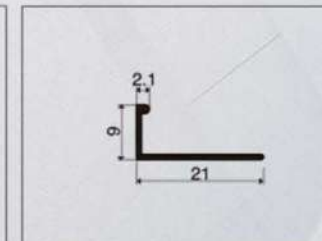
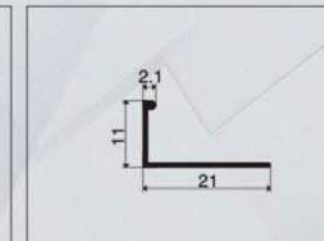
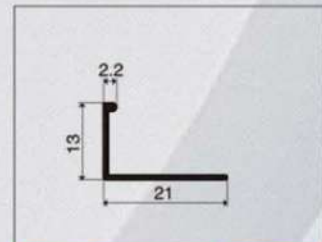
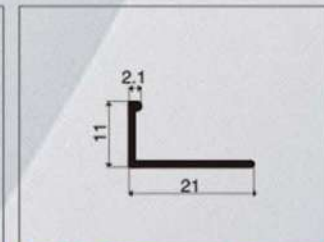
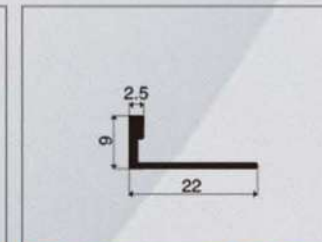
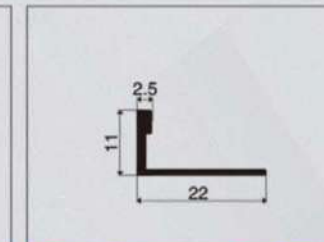
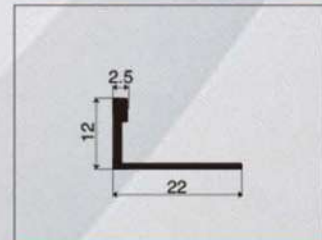
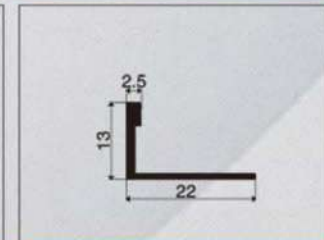
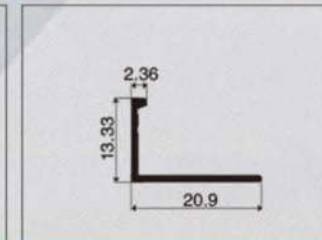
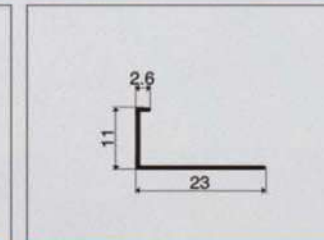
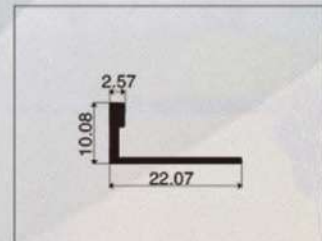
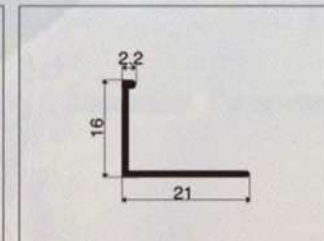
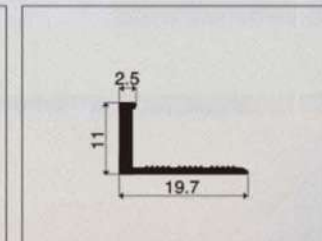
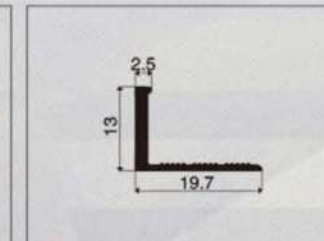
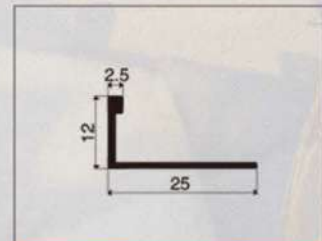
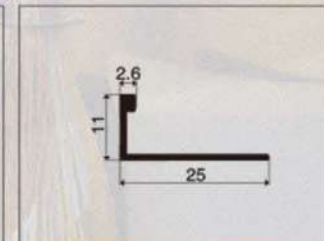
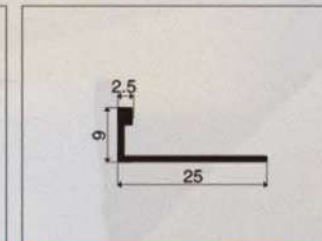
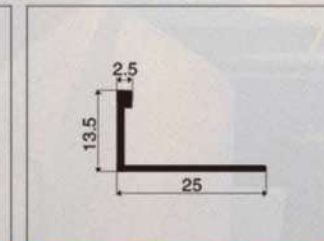
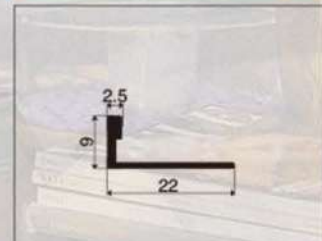
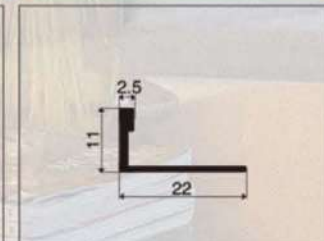
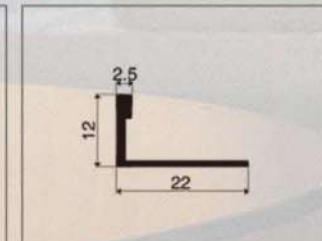
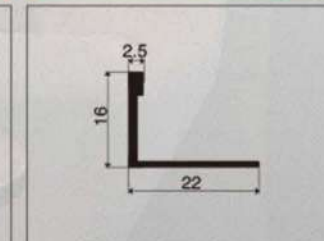
 HM-L-023 0.091kg/m	 HM-L-025 0.085kg/m	 HM-L-039 0.067kg/m	 HM-L-040 0.072kg/m
 HM-L-041 0.076kg/m	 HM-L-060 0.088kg/m	 HM-L-083 0.103kg/m	 HM-L-084 0.11kg/m
 HM-L-085 0.115kg/m	 HM-L-086 0.119kg/m	 HM-L-091 0.095kg/m	 HM-L-094 0.066kg/m
 HM-L-102 0.114kg/m	 HM-L-104 0.102kg/m	 HM-L-112 0.113kg/m	 HM-L-113 0.124kg/m
 HM-L-123 0.115kg/m	 HM-L-124 0.11kg/m	 HM-L-125 0.103kg/m	 HM-L-126 0.119kg/m
 HM-L-137 0.103kg/m	 HM-L-138 0.11kg/m	 HM-L-139 0.115kg/m	 HM-L-175 0.131kg/m

27

# STRAIGHT EDGE TRIM

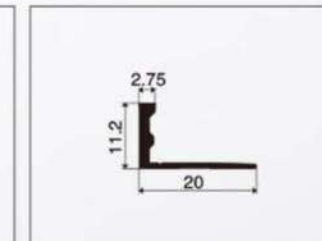
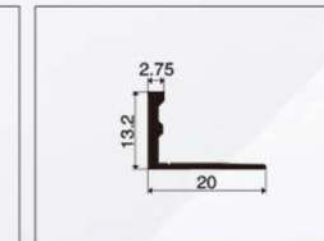
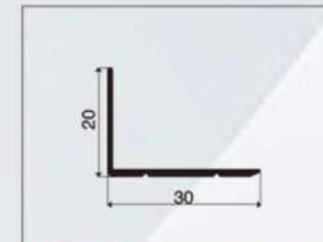
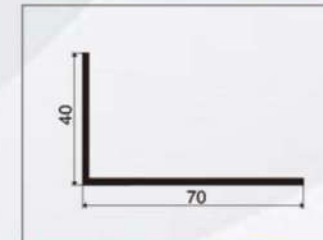
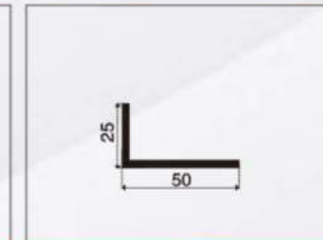
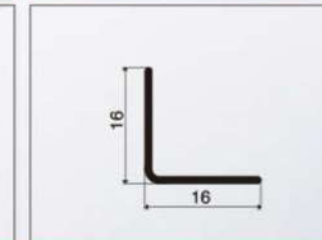
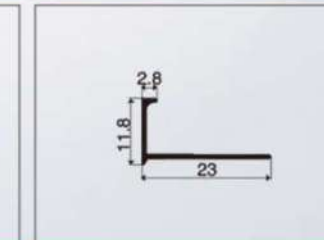
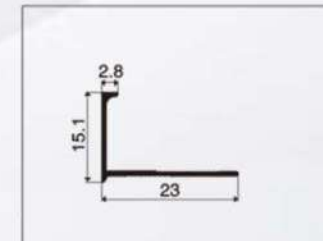
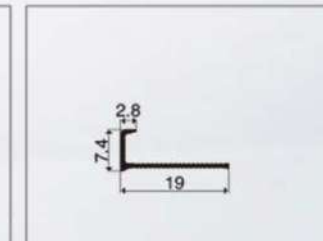
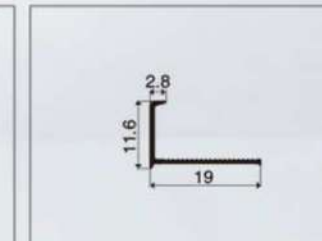
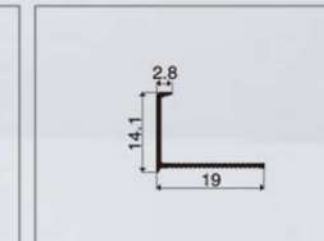
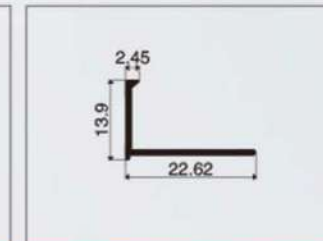
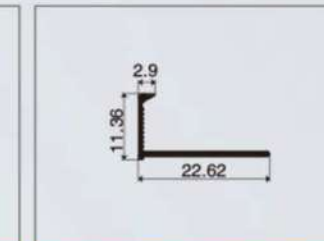
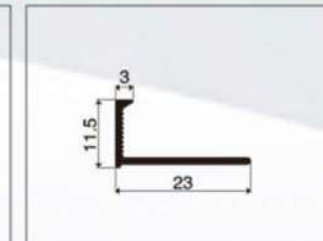
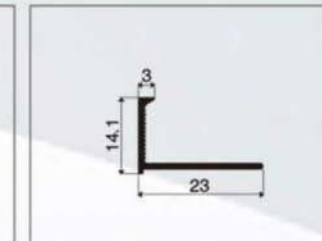
 HM-L-028 0.104kg/m	 HM-L-050 0.102kg/m	 HM-L-051 0.109kg/m	 HM-L-052 0.119kg/m
 HM-L-028 0.99kg/6m	 HM-L-064 0.136kg/m	 HM-L-108 0.465kg/m	 HM-L-109 0.71kg/m
 HM-L-110 0.587kg/m	 HM-L-111 0.588kg/m	 HM-L-114 0.082kg/m	 HM-L-070 0.078kg/m
 HM-L-071 0.085kg/m	 HM-L-072-061E1 0.052kg/m	 HM-L-073-061G 0.061kg/m	 HM-L-074-061H 0.066kg/m
 HM-L-075-061F 0.056kg/m	 HM-L-088 0.104kg/m	 HM-L-092 0.115kg/m	 HM-L-122 0.09kg/m
 HM-L-129 0.097kg/m	 HM-L-130 0.11kg/m	 HM-L-132 0.118kg/m	 HM-L-295 0.159kg/m

28

# STRAIGHT EDGE TRIM

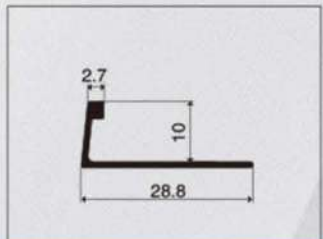
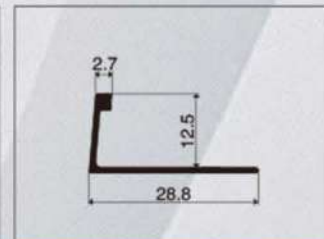
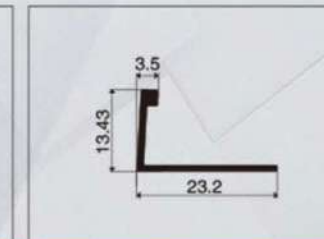
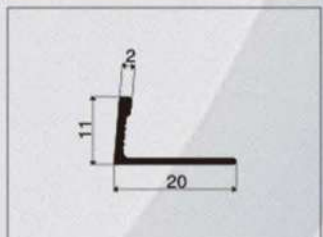
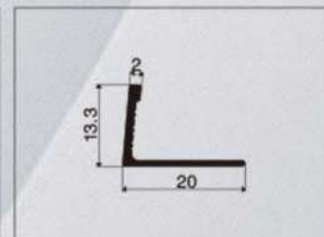
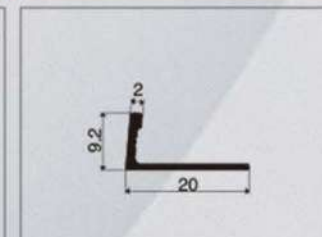
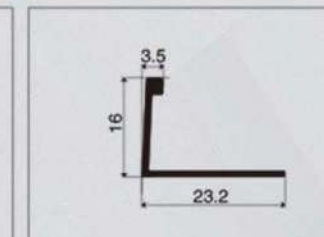
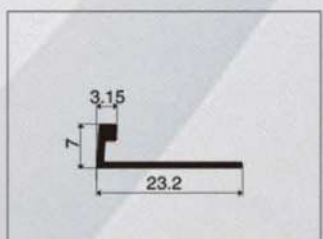
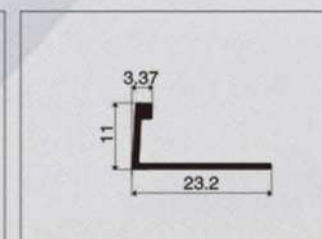
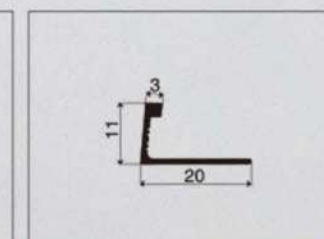
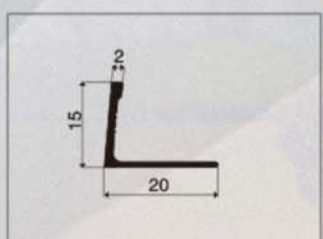
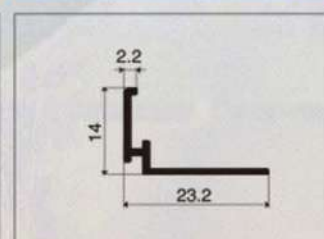
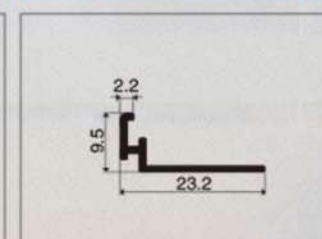
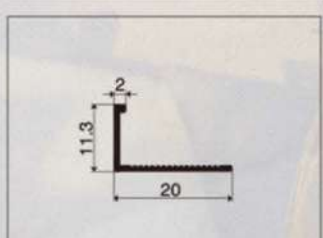
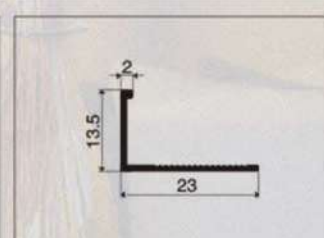
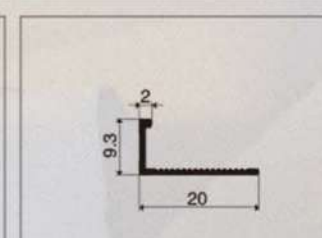
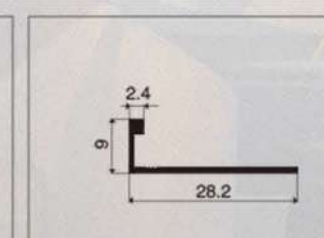
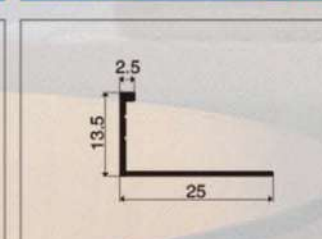
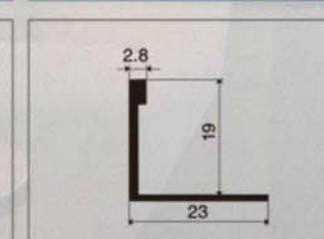
 HM-L-079 0.12kg/m	 HM-L-080 0.126kg/m	 HM-L-087 0.113kg/m	 HM-L-087 0.116kg/m
 HM-L-096 0.097kg/m	 HM-L-097 0.104kg/m	 HM-L-098 0.09kg/m	 HM-L-103 0.121kg/m
 HM-L-105 0.094kg/m	 HM-L-106 0.1kg/m	 HM-L-107 0.106kg/m	 HM-L-115 0.096kg/m
 HM-L-117 0.113kg/m	 HM-L-007 0.118kg/m	 HM-L-008 0.103kg/m	 HM-L-009 0.113kg/m
 HM-L-010 0.08kg/m	 HM-L-011 0.094kg/m	 HM-L-012 0.075kg/m	 HM-L-013 0.105kg/m
 HM-L-019 0.087kg/m	 HM-L-020 0.090kg/m	 HM-L-022 0.094kg/m	 HM-L-024 0.154kg/m

# STRAIGHT EDGE TRIM

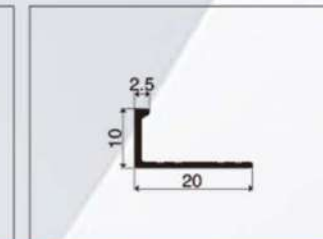
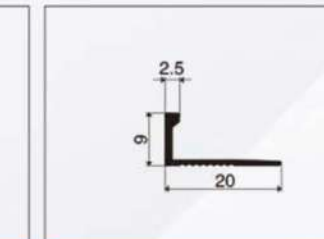
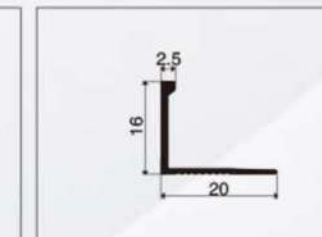
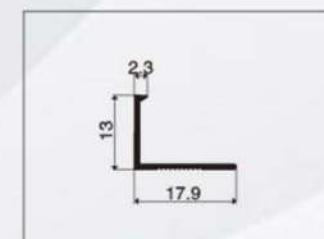
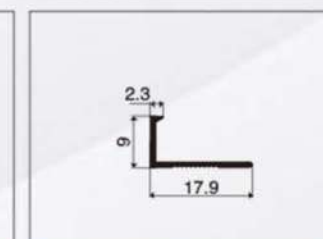
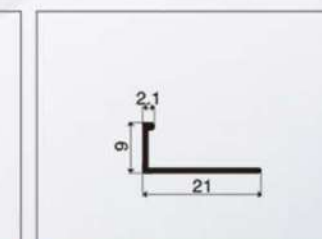
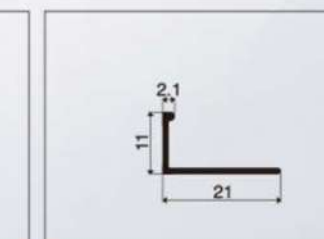
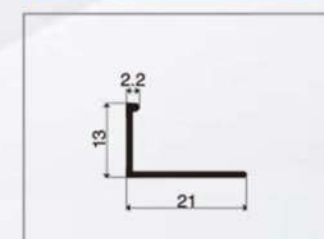
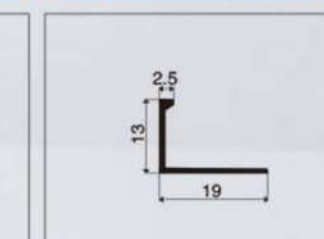
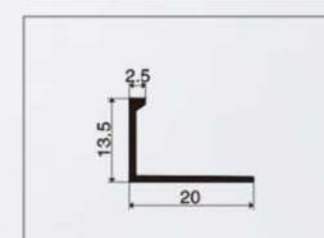
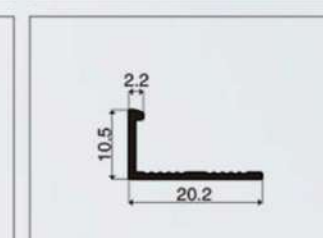
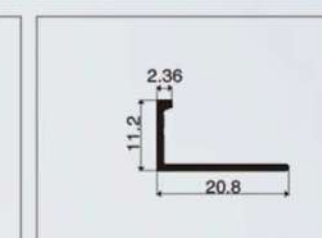
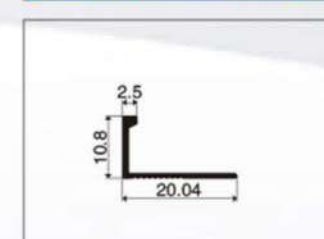
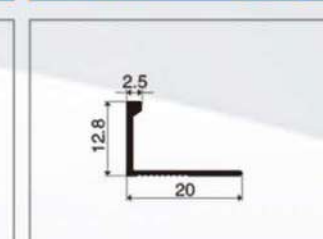
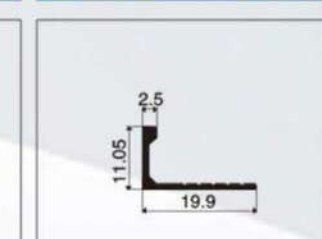
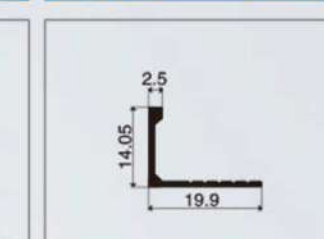
 HM-L-018 0.083kg/m	 HM-L-026 0.086kg/m	 HM-L-027 0.096kg/m	 HM-L-043 0.083kg/m
 HM-L-044 0.088kg/m	 HM-L-045 0.096kg/m	 HM-L-046 0.107kg/m	 HM-L-047 0.075kg/m
 HM-L-048 0.08kg/m	 HM-L-049 0.07kg/m	 HM-L-059 0.075kg/m	 HM-L-060 0.088kg/m
 HM-L-061 0.093kg/m	 HM-L-067 0.074kg/m	 HM-L-068 0.08kg/m	 HM-L-069 0.085kg/m
 HM-L-076 0.092kg/m	 HM-L-082 0.08kg/m	 HM-L-090 0.091kg/m	 HM-L-134 0.071kg/m
 HM-L-135 0.074kg/m	 HM-L-136 0.081kg/m	 HM-L-181 0.097kg/m	 HM-L-182 0.107kg/m

# STRAIGHT EDGE TRIM

HM031 0.093kg/m	HM031 0.088kg/m	HM-L-014 0.093kg/m	HM-L-015 0.098kg/m
HM-L-016 0.105kg/m	HM-L-017 0.113kg/m	HM-L-054 0.1kg/m	HM-L-055 0.11kg/m
HM-L-056 0.12kg/m	HM-L-057 0.12kg/m	HM-L-093 0.15/kg/m	HM-L-099 0.081kg/m
HM-L-099 0.075kg/m	HM-L-100 0.075kg/m	HM-L-101 0.081kg/m	HM-L-118 0.065kg/m
HM-L-119 0.07kg/m	HM-L-120 0.095kg/m	HM-L-003 0.124kg/m	HM-L-004 0.117kg/m
HM-L-005 0.131kg/m	HM-L-006 0.136kg/m	HM-L-053 0.118kg/m	HM-L-078 0.115kg/m

31

# STRAIGHT EDGE TRIM

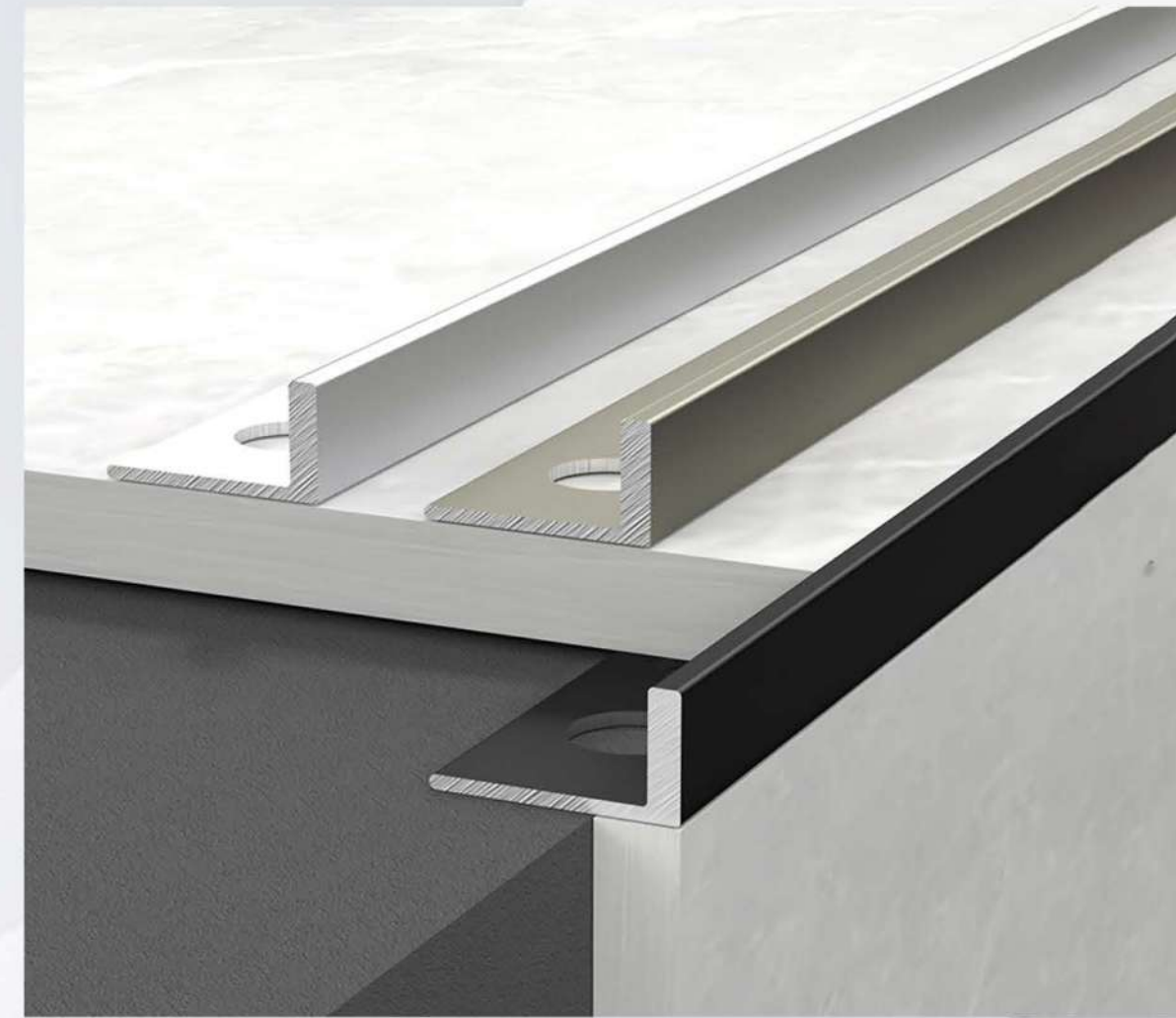

32

L360	L380	L328	L7831
L310	L3150	L325	L330
L3120	L3180		

**BOX EDGE TRIM**



**BOX EDGE TRIM**

33

**BOX EDGE TRIM**

**BOX-SHAPED TRIM** is a versatile edging profile. Its squared design provides a clean and modern finish to tiled surfaces. Its primary advantages is its ability to protect tile edges from chipping or damage, ensuring the longevity of tile installations. Box-shaped trim is ideal for various applications, including bathrooms, kitchens and commercial spaces, where it helps achieve a sleek and polished look.

**ACCESSORIES**

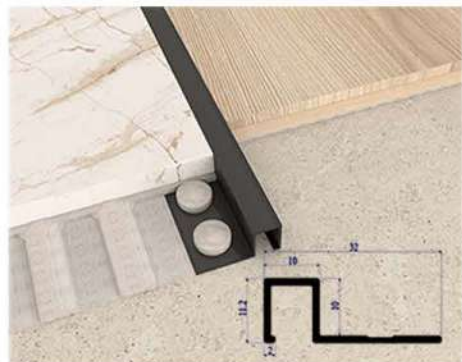

**BOX EDGE TRIM**

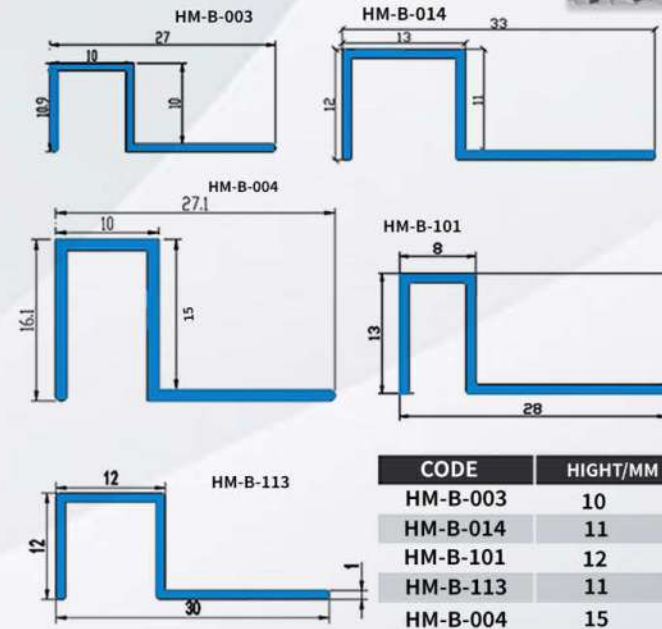
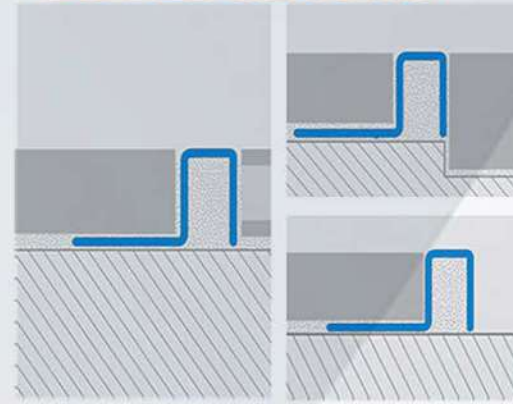

**Installation procedure**

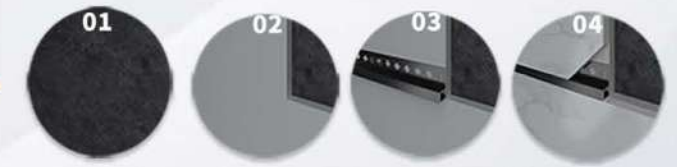

1. Choose THE BOX-SHAPED TRIM with the same height as the thickness of the covering. 2. Apply the adhesive onto the area of application of the profile. 3. Lay and align the profile pressing the perforated flange into the adhesive. 4. Lay the tiles, aligning them so that the top edge of the profile is "flush" with the tile. 5. Use the adhesive to seal any empty interstices.



34

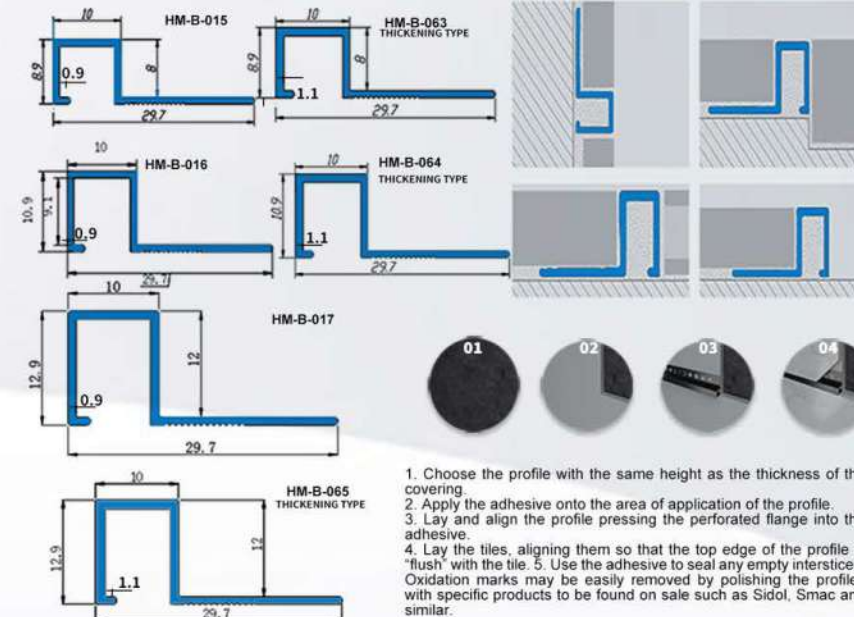

1. Choose the profile with the same height as the thickness of the covering. 2. Apply the adhesive onto the area of application of the profile. 3. Lay and align the profile pressing the perforated flange into the adhesive. 4. Lay the tiles, aligning them so that the top edge of the profile is "flush" with the tile. 5. Use the adhesive to seal any empty interstices. Oxidation marks may be easily removed by polishing the profiles with specific products to be found on sale such as Sidol, Smac and similar.



CODE	HIGHT/MM	WEIGHT KG/M
HM-B-015	8	0.112
HM-B-016	10	0.112
HM-B-017	12	0.132
HM-B-063 THICKENING TYPE	8	0.121
HM-B-064 THICKENING TYPE	10	0.132
HM-B-065 THICKENING TYPE	12	0.143

## BOX EDGE TRIM

### BOX EDGE TRIM

#### EXAMPLES AND INSTRUCTIONS FOR LAYING METHODS

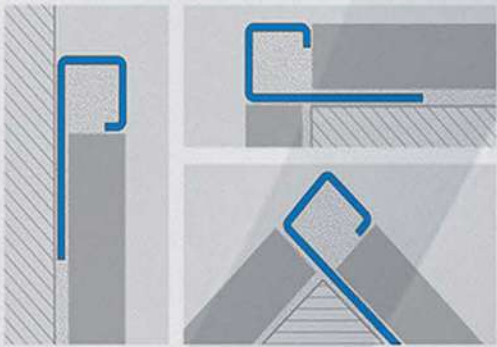

1. Choose a Box Edge Trim height corresponding to the thickness of the covering/floor. 2. Apply the adhesive in the area that the square is being applied. 3. Rest and line up the square, cut to the required length, pressing the perforated tab into the adhesive. 4. Place the tiles lining them up so that the upper part of the square meets with their edge. 5. Fill the contact area between square and tile completely with adhesive to prevent the accumulation of water in the empty spaces.

CODE	HIGHT/MM	KG/M
HM-B-026	10	0.144
HM-B-055	10	0.12
HM-B-145	12.5	0.16



Application

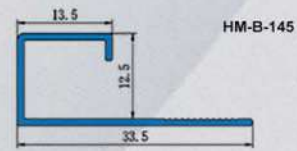

HM-B-145

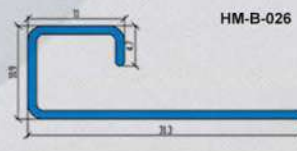

HM-B-026



HM-B-055

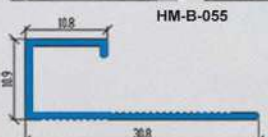

35

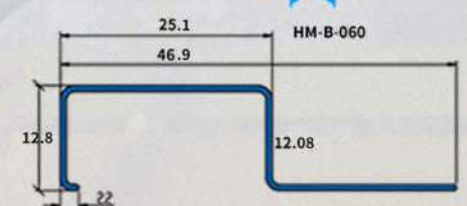
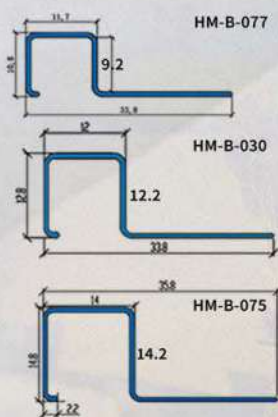

CODE	HIGHT/MM	KG/M
HM-B-077	9	0.115
HM-B-030	12	0.106
HM-B-060	12	0.137
HM-B-075	14	0.118

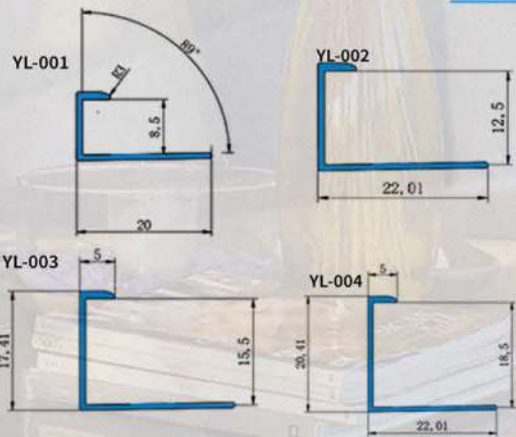

#### EXAMPLES AND INSTRUCTIONS FOR LAYING METHODS

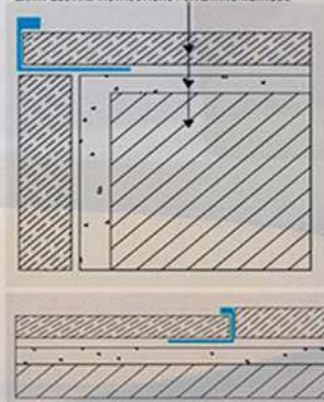

CODE	HIGHT/MM	KG/M
YL-001	8.5	0.076
YL-002	12.5	0.089
YL-003	15.5	0.096
YL-004	18.5	0.102

## BOX EDGE TRIM



Application

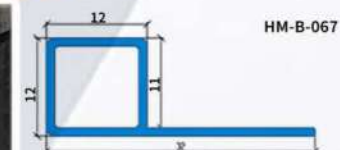

HM-B-067

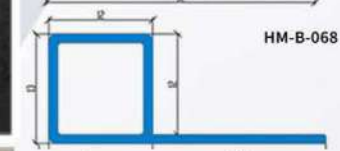

HM-B-068

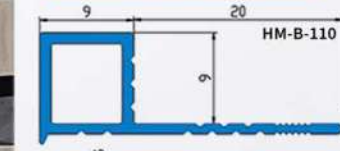

HM-B-110

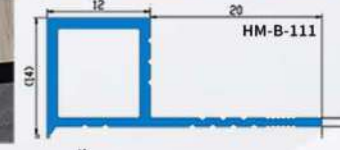

HM-B-111

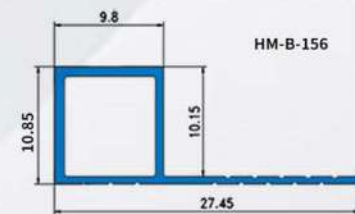

HM-B-156

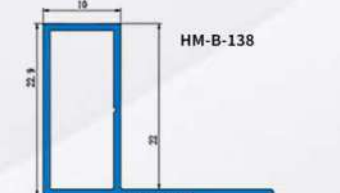

HM-B-138

#### EXAMPLES AND INSTRUCTIONS FOR LAYING METHODS

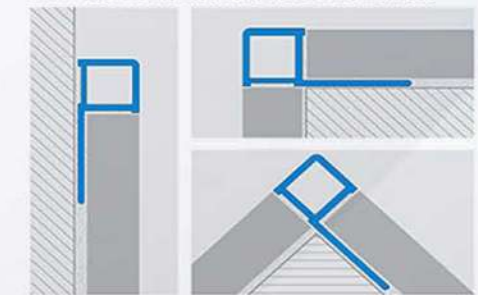

1. Choose a Box Edge Trim height corresponding to the thickness of the covering/floor. 2. Apply the adhesive in the area that the square is being applied. 3. Rest and line up the square, cut to the required length, pressing the perforated tab into the adhesive. 4. Place the tiles lining them up so that the upper part of the square meets with their edge. 5. Fill the contact area between square and tile completely with adhesive to prevent the accumulation of water in the empty spaces.

CODE	HIGHT/MM	KG/M
HM-B-110	9	0.147
HM-B-156	10	0.160
HM-B-067	11	0.173
HM-B-068	12	0.178
HM-B-111	12	0.191
HM-B-138	22	0.197

#### EXAMPLES AND INSTRUCTIONS FOR LAYING METHODS

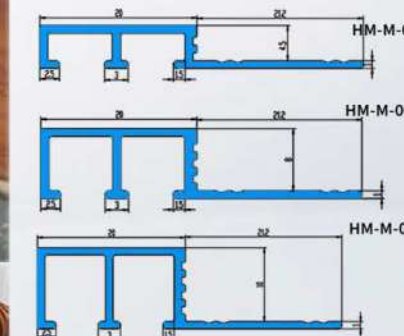

CODE	HIGHT/MM	KG/M
HM-M-001	4.5	0.162
HM-M-002	8	0.194
HM-M-003	10	0.211

1. Choose the Box Edge Trim 20 surface finish whose height corresponds to covering thickness. 2. Apply the adhesive in the area that the square is being applied. 3. Rest and line up the square, cut to the required length, pressing the perforated tab into the adhesive. 4. Lay the tiles/ ceramic tiles or apply the resin, lining it up so that the upper part of the square meets with their edge Profile. Pay attention to the external edges of the aluminium profile. They must be protected against agents such as adhesives and sealants and against grinding or scraping actions.

CODE	HIGHT/MM	KG/M
4274886	33	0.251
HM-P-024	39	0.214

#### EXAMPLES AND INSTRUCTIONS FOR LAYING METHODS

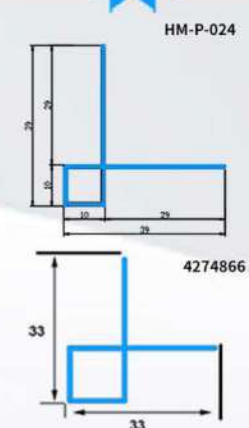



HM-P-024

4274886

36

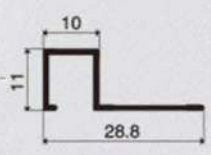
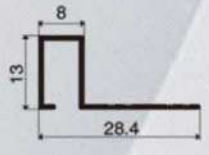
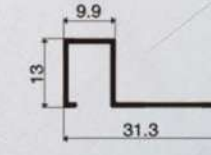
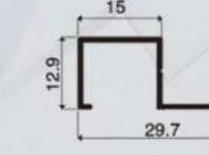
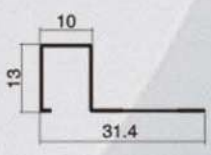
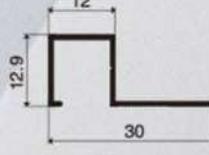
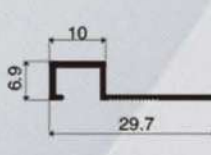
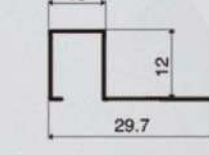
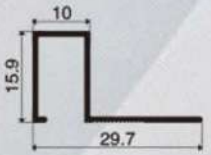
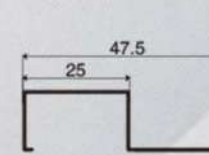
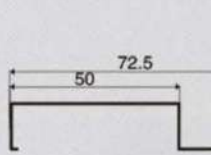
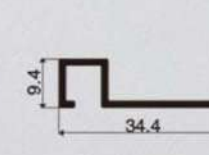
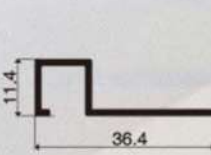
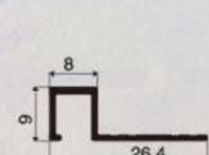
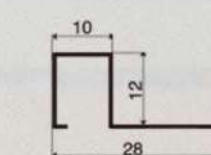
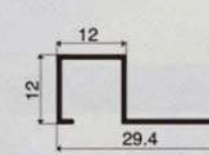
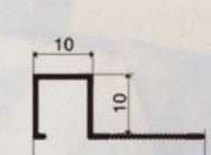
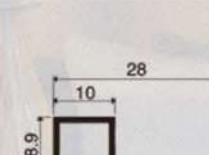
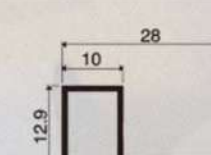
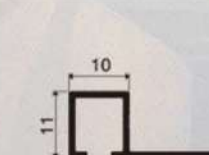
# BOX EDGE TRIM

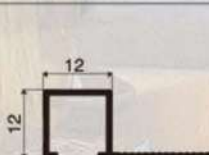
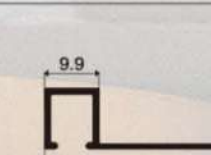
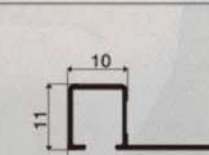
 HM-B-109 0.129kg/m	 HM-B-114 0.131kg/m	 HM-B-117 0.135kg/m	 HM-B-121 0.132kg/m
 HM-B-124 0.088kg/m	 HM-B-125 0.133kg/m	 HM-B-127 0.110kg/m	 HM-B-130 0.09kg/m
 HM-B-137 0.147kg/m	 HM-B-139 0.145kg/m	 HM-B-140 0.192kg/m	 HM-B-141 0.178kg/m
 HM-B-142 0.199kg/m	 HM-B-149 0.119kg/m	 HM-B-150 0.086kg/m	 HM-B-151 0.117kg/m
 HM-B-153 0.11kg/m	 HM-B-005 0.116kg/m	 HM-B-006 0.136kg/m	 HM-B-078 0.141kg/m
 HM-B-079 0.152kg/m	 HM-B-099 0.145kg/m	 HM-B-118 0.163kg/m	 HM-B-131 0.107kg/m

37

# BOX EDGE TRIM

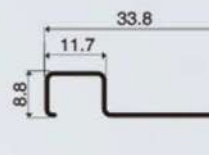
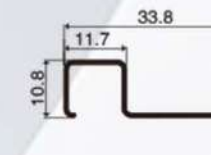
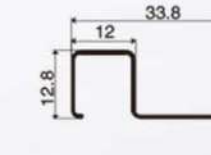
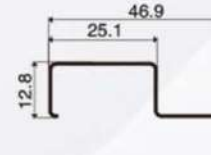
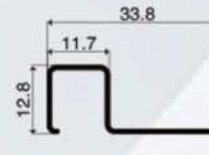
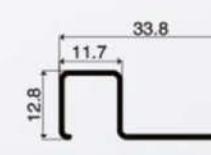
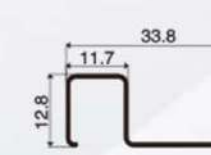
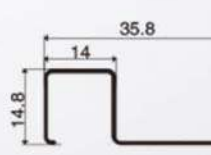
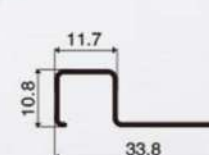
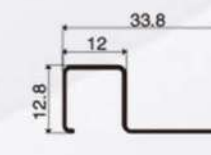
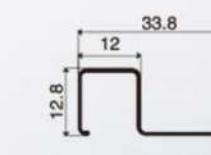
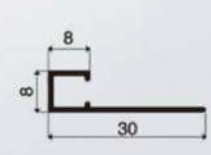
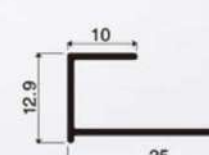
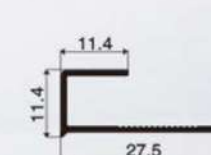
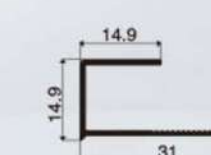
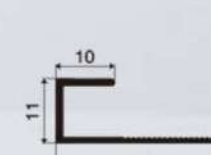
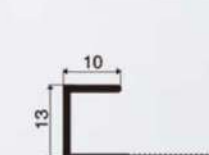
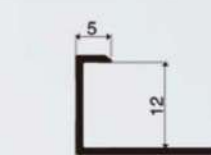
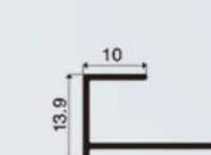
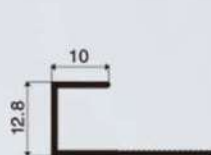
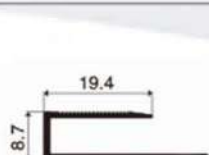
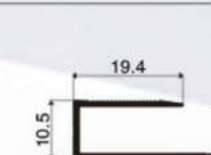
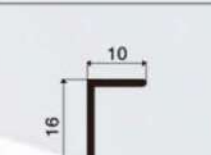
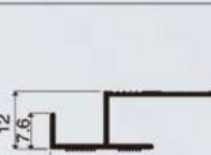
 HM-B-013 0.11kg/m	 HM-B-014 0.119kg/m	 HM-B-030 0.106kg/m	 HM-B-060 0.137kg/m
 HM-B-061 0.124kg/m	 HM-B-062 0.124kg/m	 HM-B-066 0.116kg/m	 HM-B-075 0.118kg/m
 HM-B-077 0.115kg/m	 HM-B-106 0.105kg/m	 HM-B-112 0.105kg/m	 HM-B-021 0.124kg/m
 HM-B-010 0.67kg/6m	 HM-B-056 0.125kg/m	 HM-B-057 0.154kg/m	 HM-B-073 0.133kg/m
 HM-B-074 0.139kg/m	 HM-B-086 0.1kg/m	 HM-B-093 0.115kg/m	 HM-B-094 0.128kg/m
 HM-B-095 0.153kg/m	 HM-B-096 0.158kg/m	 HM-B-105 0.149kg/m	 HM-B-013 0.176kg/m

38

# BOX EDGE TRIM

BT470 0.108kg/m	HM-B-003 0.115kg/m	HM-B-004 0.170kg/m	HM-B-014 0.150kg/m
HM-B-027 0.118kg/m	HM-B-028 0.106kg/m	HM-B-032 0.16kg/m	HM-B-069 0.166kg/m
HM-B-071 0.094kg/m	HM-B-082 0.154kg/m	HM-B-101 0.141kg/m	HM-B-113 0.14kg/m
HM-B-135 0.151kg/m	HM-B-136 0.164kg/m	HM-B-001 0.109kg/m	HM-B-002 0.102kg/m
HM-B-007 0.139kg/m	HM-B-008 0.15kg/m	HM-B-009 0.099kg/m	HM-B-011 0.123kg/m
HM-B-012 0.16kg/m	HM-B-015 0.112kg/m	HM-B-016 0.122kg/m	HM-B-017 0.132kg/m

39



# BOX EDGE TRIM

HM-B-020 0.123kg/m	HM-B-024 0.151kg/m	HM-B-025 0.188kg/m	HM-B-031 0.105kg/m
HM-B-040 0.16kg/m	HM-L-070 0.176kg/m	HM-B-059 0.114kg/m	HM-B-063 0.121kg/m
HM-B-064 0.132kg/m	HM-B-065 0.143kg/m	HM-B-072 0.115kg/m	HM-B-076 0.107kg/m
HM-B-080 0.132kg/m	HM-B-081 0.142kg/m	HM-B-083 0.155kg/m	HM-B-087 0.136kg/m
HM-B-088 0.111kg/m	HM-B-089 0.106kg/m	HM-B-090 0.098kg/m	HM-B-092 0.108kg/m
HM-B-097 0.174kg/m	HM-B-098 0.194kg/m	HM-B-107 0.088kg/m	HM-B-108 0.121kg/m

40



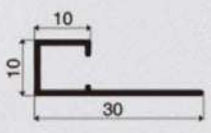
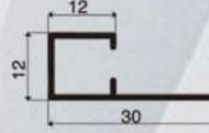
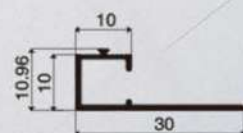
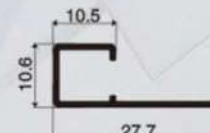
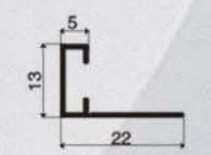
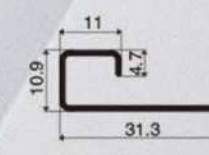
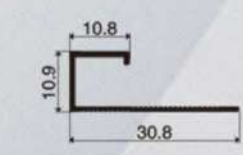
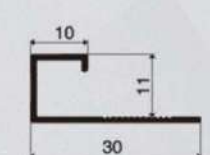
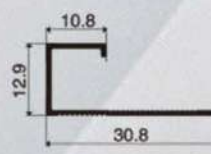
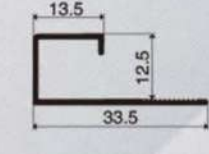
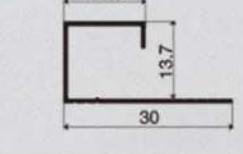
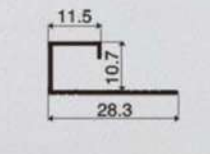
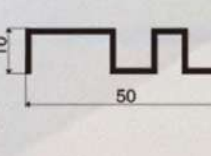
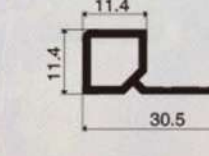
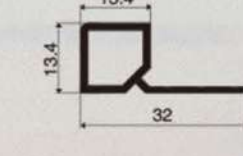
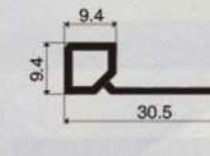
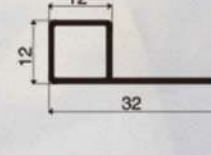
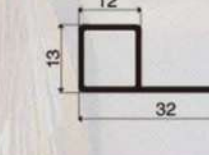
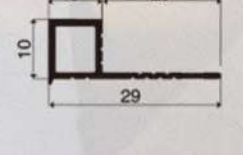
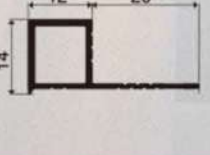

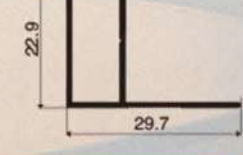
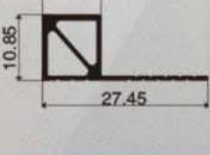
# BOX EDGE TRIM

			
HM-B-022 0.138kg/m	HM-B-023 0.154kg/m	HM-B-070 0.136kg/m	HM-B-119 0.133kg/m
			
HM-B-122 0.105kg/m	HM-B-026 0.144kg/m	HM-B-055 0.12kg/m	HM-B-104 0.136kg/m
			
HM-B-115 0.126kg/m	HM-B-145 0.16kg/m	HM-B-147 0.122kg/m	HM-B-148 0.113kg/m
			
HM-B-033 0.278kg/m	HM-B-036 0.214kg/m	HM-B-037 0.243kg/m	HM-B-038 0.19kg/m
			
HM-B-067 0.173kg/m	HM-B-068 0.178kg/m	HM-B-110 0.147kg/m	HM-B-111 0.191kg/m
			
HM-B-128 0.147kg/m	HM-B-129 0.191kg/m	HM-B-138 0.197kg/m	HM-B-154 0.142kg/m

41

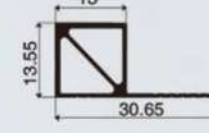
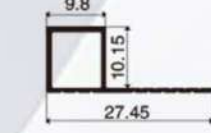
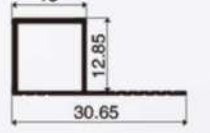
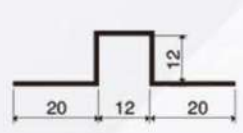
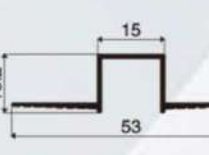
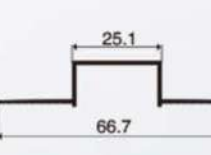
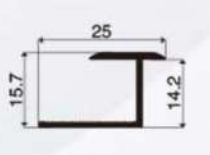
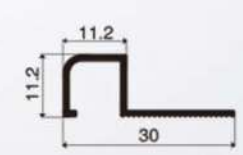
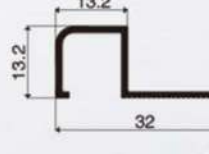
# BOX EDGE TRIM

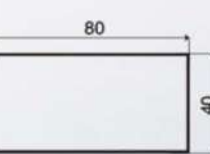
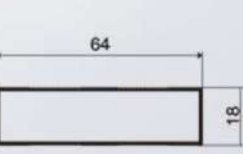
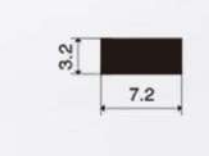
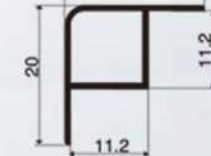
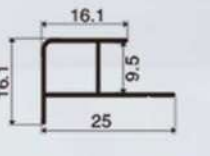
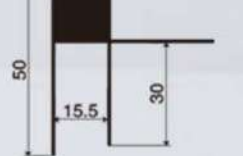
			
HM-B-155 0.175kg/m	HM-B-156 0.114kg/m	HM-B-157 0.14kg/m	HM-P-065 0.207kg/m
			
HM-B-084 0.213kg/m	HM-B-085 0.254kg/m	HM-B-100 0.159kg/m	HM-B-133 0.159kg/m
			
HM-B-134 0.178kg/m	HM-B-029 0.595kg/m	HM-B-152 0.587kg/m	HM-P-076 0.414kg/m
			
HM-P-048 0.063kg/m	HM-R-141 0.129kg/m	HM-P-044 0.122kg/m	HM-P-121 0.411kg/m

42

TRIANGULAR EDGE TRIM



43

# Triangular Edge Trim

TRIANGULAR EDGE TRIM is a unique edging profile characterized by its triangular cross-section, designed to provide a sleek and protective finish to tile edges. Its key advantages lie in its ability to enhance aesthetics, protect against wear and damage and facilitate easy maintenance. Triangle trim is primarily employed in interior tiling projects, including bathrooms, kitchens and commercial spaces, where it ensures a polished and durable edge for tiles.

ACCESSORIES



## Triangular Edge Trim

EXAMPLES AND INSTRUCTIONS FOR LAYING METHODS

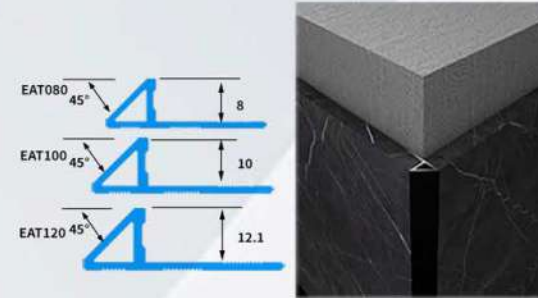
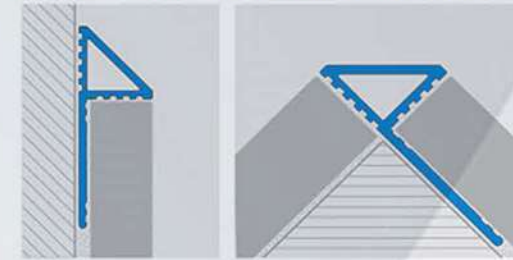

CODE	HIGHT/MM	WEIGHT KG/M
EAT080	8	0.112
EAT100	10	0.155
EAT120	12.1	0.115



TRIANGULAR EDGE TRIM

Installation procedure



1. Choose Triangular Edge Trim according to the thickness of the tile and in the desired finish. 2. Cut Straight edge trim to the desired length and apply the adhesive on the support where the profile will be laid. 3. Press the anchoring flange of Triangular Edge Trim into the adhesive. 4. Lay the tiles, aligning them with the profile and leaving a 2 mm joint. Remove immediately all the remains of adhesive from the surface of the profile. 5. Fill the joints between the profile and the tile with plaster in order to avoid water stagnation. Remove immediately all the remains of plaster from the surface of the profile.

EXAMPLES AND INSTRUCTIONS FOR LAYING METHODS

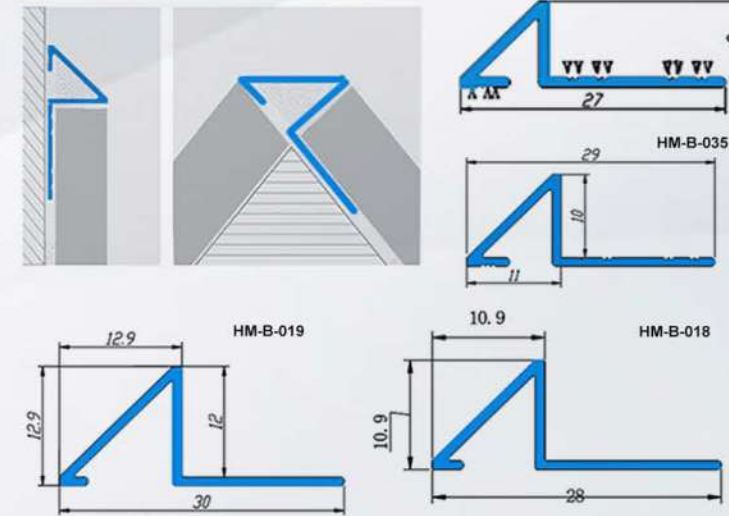

CODE	HIGHT/MM	WEIGHT KG/M
HM-B-034	8	0.112
HM-B-035	10	0.126
HM-B-018	10	0.108
HM-B-019	12	0.120

44

EXAMPLES AND INSTRUCTIONS FOR LAYING METHODS

CODE	HIGHT/MM	WEIGHT KG/M
HM033	12.5	0.188

1. Choose Triangular Edge Trim according to the tile thickness and desired finish. 2. Cut Triangular Edge Trim to the desired length and apply the adhesive on the support where the profile will be laid. 3. Press the anchoring flange of Triangular Edge Trim into the adhesive. 4. Lay the tiles, aligning them with the profile leaving a 2 mm joint. Remove immediately all remains of adhesive from the surface of the profile. 5. Fill the joints between the profile and the tiles with grout, in order to avoid water stagnation. Remove immediately all the remains of grout from the surface of the profile.

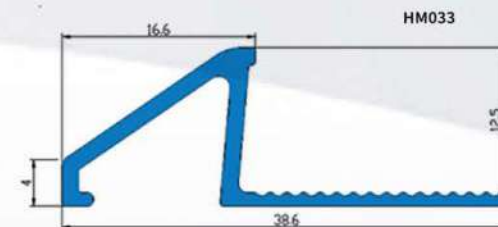

**DIVIDING STRIP**



**DIVIDING STRIP**

45

**DIVIDING STRIP**

DIVIDING STRIP is a versatile edging profile characterized by its Dividing Strip-cross-section. Its main advantage is to provide a clean, protective finish for tile edges, enhancing aesthetics and safeguarding against damage. It finds extensive application in various tile installations, including floors, walls and countertops, ensuring a polished look while ensuring tile longevity.

**Application**



**DIVIDING STRIP**

EXAMPLES AND INSTRUCTIONS FOR LAYING METHODS



**DIVIDING STRIP**

**Application**



**Installation procedure**

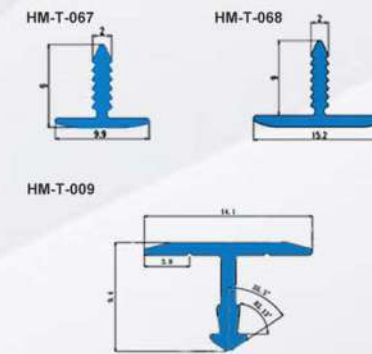

1. Choose the DIVIDING STRIP with the width suitable for the gap between the two floors to be joined, taking into consideration 2/3 mm side lap. 2. Fill the gap with single-pack silicone or with the adhesive used for laying the floor. 3. Bury the profile into the adhesive, making sure that both side laps of the profile rest on the coverings to be joined.

CODE	HIGHT/MM	KG/M
HM-T-067	8*9.9	0.06
HM-T-068	9*15.2	0.095
HM-T-009	8.3*14	0.073



46

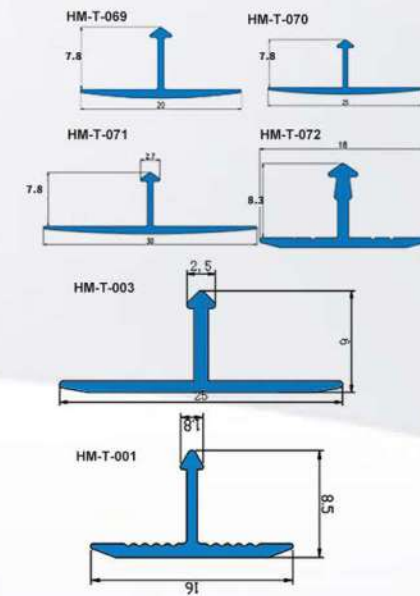

EXAMPLES AND INSTRUCTIONS FOR LAYING METHODS

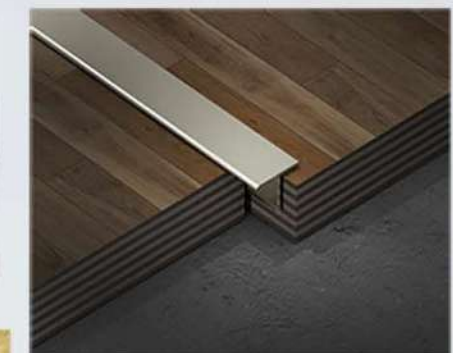
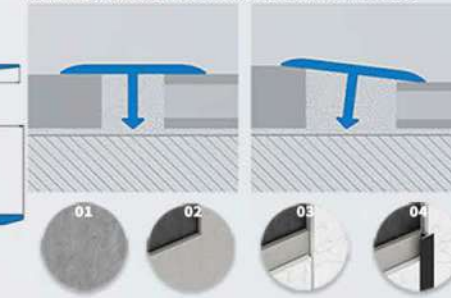

CODE	HIGHT/MM	KG/M
HM-T-003	8*16	0.094
HM-T-072	8.3*18	0.08
HM-T-069	7.8*20	0.067
HM-T-070	7.8*25	0.080
HM-T-001	8.0*25	0.060
HM-T-071	7.8*30	0.091

## DIVIDING STRIP

# DIVIDING STRIP

EXAMPLES AND INSTRUCTIONS FOR LAYING METHODS

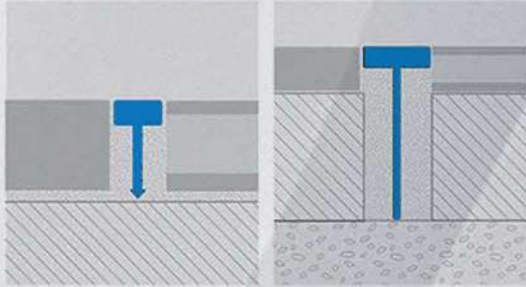

1. Choose the DIVIDING STRIP with the same height as the thickness of the floor. 2. Cut the profile to the necessary length and place it along the edge of the laid floor or insert it from above. 3. Continue the laying flush with the DIVIDING STRIP

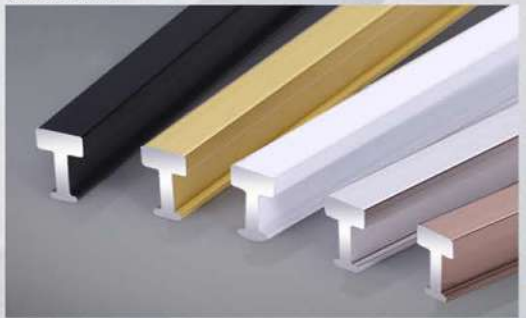

Application

### Installation procedure



CODE	H mm	KG/M
HM-T1-001	25	0.177
HM-T1-002	25	0.123
HM-T1-003	14	0.089
HM-T1-004	10	0.066



47

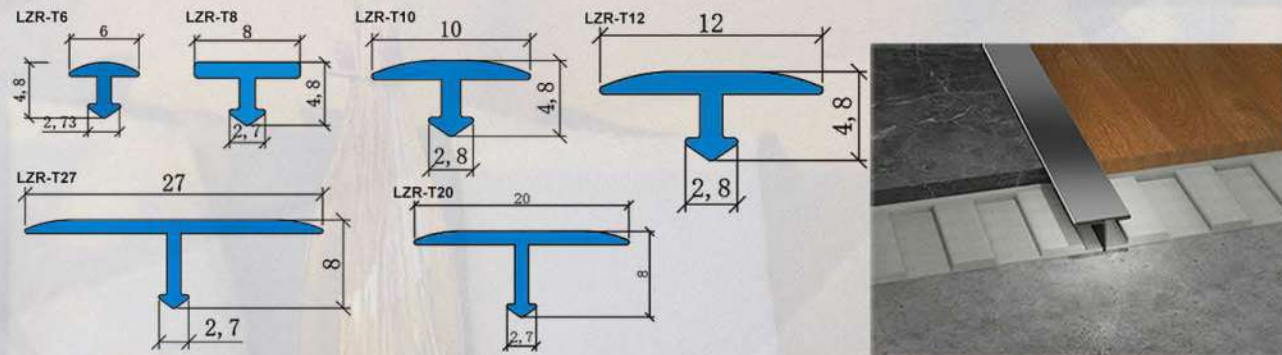

EXAMPLES AND INSTRUCTIONS FOR LAYING METHODS

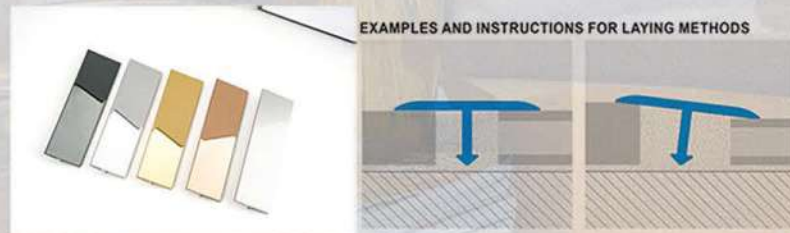

CODE	W/mm	KG/M
LZR-T6	6	0.029
LZR-T8	8	0.039
LZR-T10	10	0.04
LZR-T12	12	0.047
LZR-T20	20	0.083
LZR-T27	27	0.18

## DIVIDING STRIP

# DIVIDING STRIP

Application

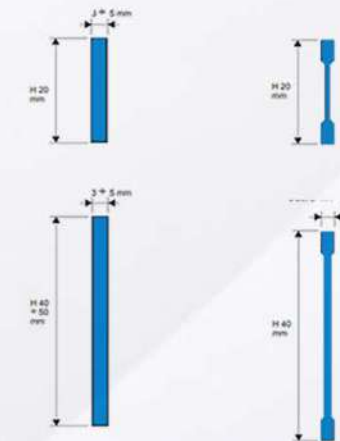

1. Choose Dividing Strip with the same height as the thickness of the floor. 2. Cut the profile to the necessary length and place it along the edge of the laid floor or insert it from above. 3. Continue the laying "flush" with the profile.

EXAMPLES AND INSTRUCTIONS FOR LAYING METHODS



48



## LISTELLO TRIM

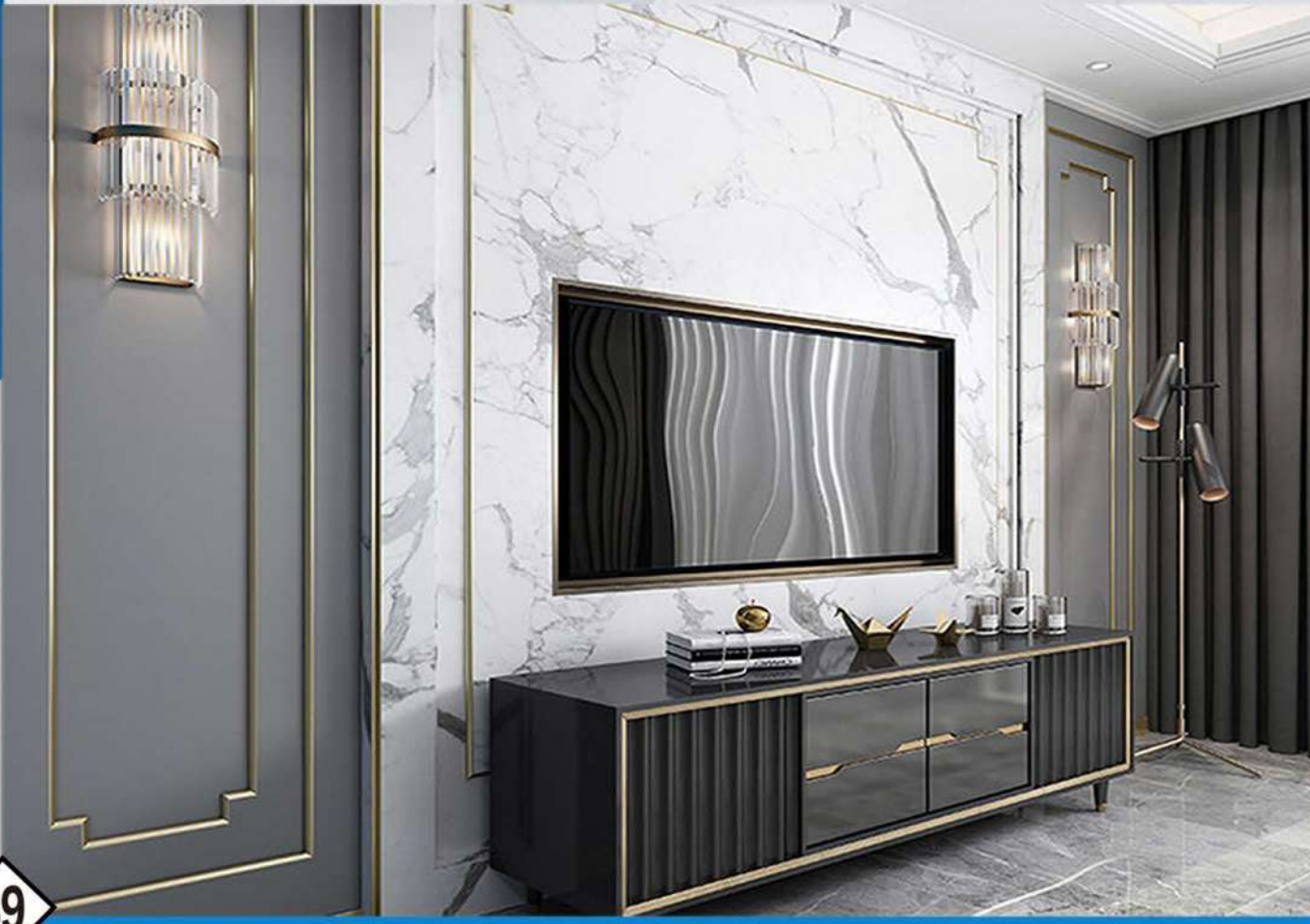

49

## LISTELLO TRIM

LISTELLO TRIM is a versatile edging profile characterized by its curved and protective design. Its main advantage lies in providing a secure and polished finish to edges, offering protection against wear and damage. It is commonly applied in scenarios such as tiling, cabinetry and furniture construction, ensuring a professional and seamless finish for both residential and commercial settings.

EXAMPLES AND INSTRUCTIONS FOR LAYING METHODS

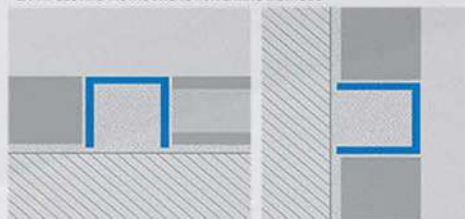

1. Choose the profile in the required material and finish. 2. Apply the adhesive onto the area of application. 3. Lay the U-shaped trim. 4. Continue laying by aligning it "flush" with the covering. 5. Use the adhesive to seal any empty interstices. Oxidation marks may be easily removed by polishing the profiles with specific products to be found on sale such as Sidol, Smac and similar.



CODE	HIGHT/MM	WEIGHT KG/M
HM-C-023	10*10*1	0.076
HM-C-028	10*10*1.2	0.104
HM-C-022	10*10*1.4	0.103
HM-C-017	12*7*1	0.065
HM-C-036	12*8*1.2	0.083
HM-C-020	25*25*1.6	0.321

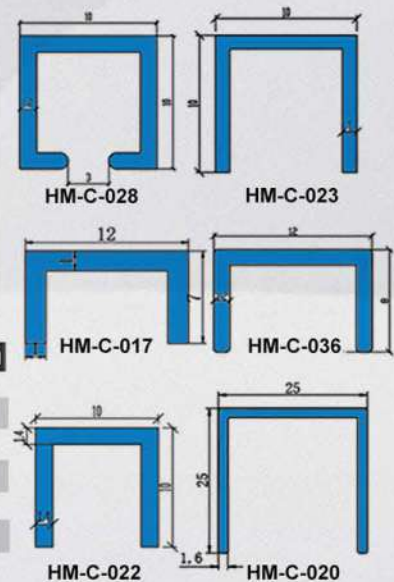

## LISTELLO TRIM

EXAMPLES AND INSTRUCTIONS FOR LAYING METHODS



1. Choose the listello Trim. 2. Spread the adhesive on the place of application. 3. Apply and align the profile, after cutting to length. 4. Lay the tiles/ceramic or spread the resin, aligning the profile so that the top is flush. IMPORTANT: Pay attention to the external edges of the aluminium prolistel. They must be protected against agents such as adhesives and sealants and against grinding or scraping actions.

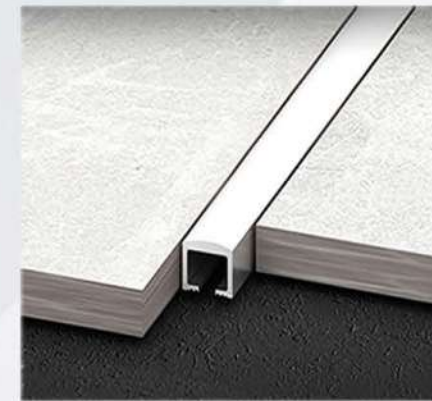

## LISTELLO TRIM

Application

CODE	WIDE*HIGHT/MM	WEIGHT KG/M
HM-C-050	9.9*8	0.114
HM-C-004	10*8.5	0.083
HM-C-006	20*7.5	0.134
HM-C-007	25*7.8	0.083

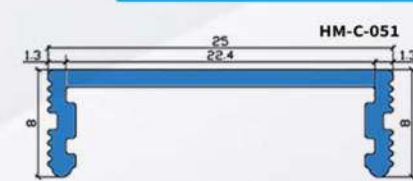

EXAMPLES AND INSTRUCTIONS FOR LAYING METHODS

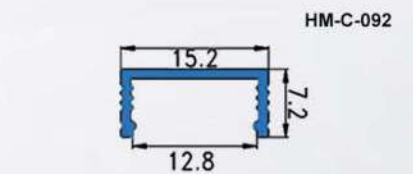

EXAMPLES AND INSTRUCTIONS FOR LAYING METHODS

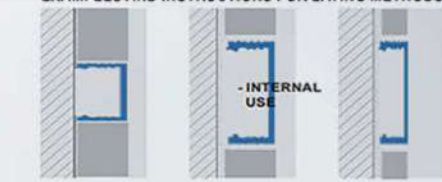

CODE	HIGHT/MM	WEIGHT KG/M
HM-C-013	8*12	0.094
HM-C-092	8*15	0.076
HM-C-051	8*25	0.139

1. Choose the listello Trim in the required width. 2. Apply the adhesive onto the area of application of the profile. 3. Lay and align the profile, cut to the necessary length, pressing it into the adhesive. 4. Lay the tiles, aligning them so that the top edge of the profile is flush with the tile. 5. Fill the profile/tile area of contact with adhesive to prevent the accumulation of water in any voids. Pay attention to the external edges of the U-shaped trim. They must be protected against agents such as adhesives and sealants and against grinding or scraping actions.

EXAMPLES AND INSTRUCTIONS FOR LAYING METHODS

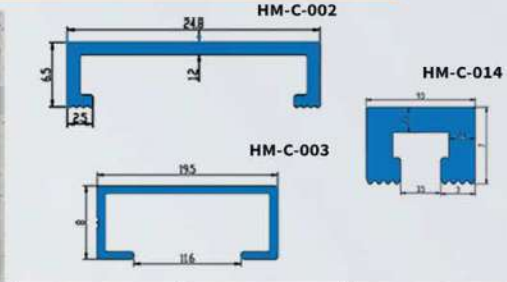
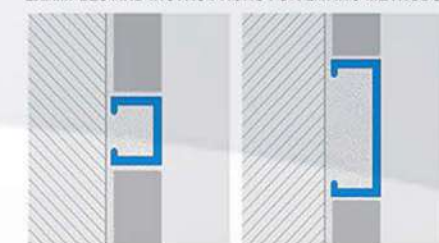

























1. Choose the listello Trim. 2. Spread the adhesive on the place of application. 3. Apply and align the profile, after cutting to length. 4. Lay the tiles/ceramic or spread the resin, aligning the profile so that the top is flush. LISTELLO TRIM: Pay attention to the external edges of the aluminium prolistel. They must be protected against agents such as adhesives and sealants and against grinding or scraping actions.



CODE	WIDE*HIGHT/MM	WEIGHT KG/M
HM-C-014	9.5*7	0.125
HM-C-012	10*8	0.067
HM-C-021	15*7	0.087
HM-C-003	19.5*8	0.087
HM-C-002	25*6.5	0.123

























50

# LISTELLO TRIM

			
HM-C-017 0.065kg/m	HM-C-018 0.195kg/m	HM-C-019 0.247kg/m	HM-C-020 0.312kg/m
			
HM-C-022 0.076kg/m	HM-C-023 0.076kg/m	HM-C-024 0.064kg/m	HM-C-025 0.092kg/m
			
HM-C-034 0.092kg/m	HM-C-036 0.083kg/m	HM-C-044 0.076kg/m	HM-C-049 0.098kg/m
			
HM-C-057 0.12kg/m	HM-C-058 0.08kg/m	HM-C-061 0.006kg/m	HM-C-063 0.085kg/m
			
HM-C-066 0.090kg/m	HM-C-070 0.092kg/m	HM-C-071 0.055kg/m	HM-C-072 0.083kg/m
			
HM-C-077 0.449kg/m	HM-C-078 0.051kg/m	HM-C-079 0.06kg/m	HM-C-085 0.298kg/m



51

# LISTELLO TRIM

			
HM-C-087 0.04kg/m	HM-C-088 0.055kg/m	HM-C-089 0.329kg/m	HM-C-090 0.162kg/m
			
HM-C-091 0.07kg/m	HM-C-094 0.117kg/m	HM-C-096 0.084kg/m	DT-0309 0.121kg/m
			
HM-C-002 0.123kg/m	HM-C-003 0.087kg/m	HM-C-005 0.074kg/m	HM-C-0012 0.071kg/m
			
HM-C-012 0.067kg/m	HM-C-014 0.125kg/m	HM-C-021 0.087kg/m	HM-C-028 0.104kg/m
			
HM-C-030 0.092kg/m	HM-C-033 0.104kg/m	HM-C-037 0.075kg/m	HM-C-039 0.074kg/m
			
HM-C-040 0.064kg/m	HM-C-041 0.053kg/m	HM-C-042 0.096kg/m	HM-C-043 0.147kg/m

52

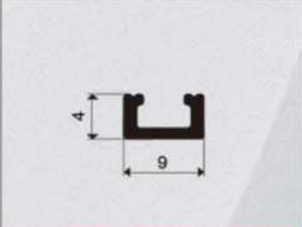
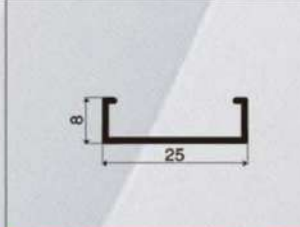
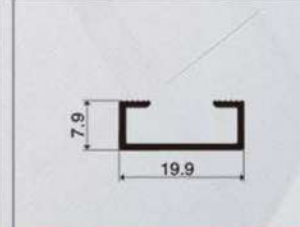
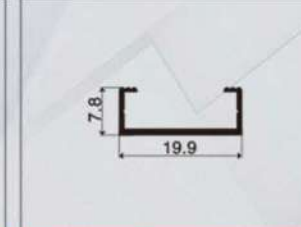
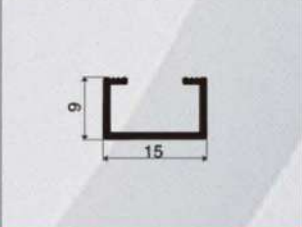
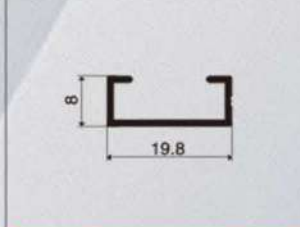
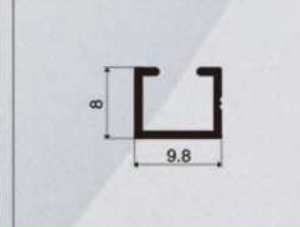
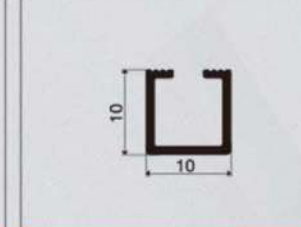
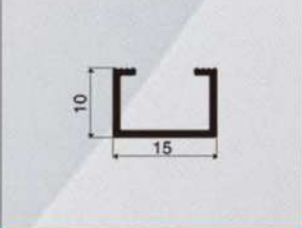
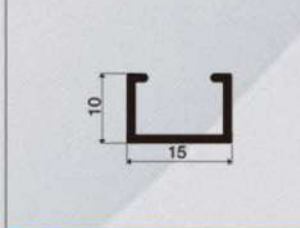
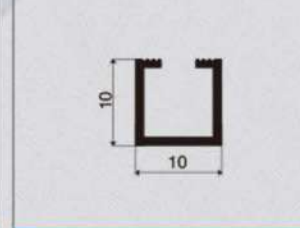
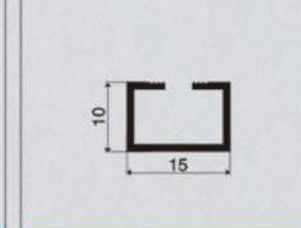
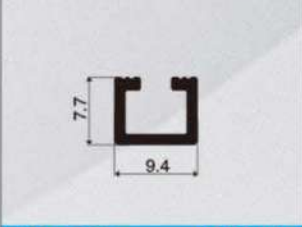
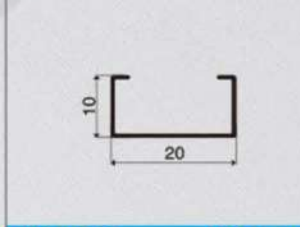
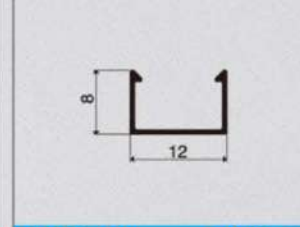
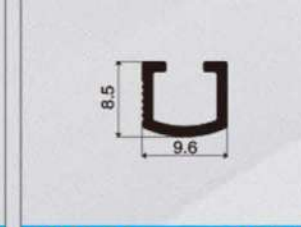
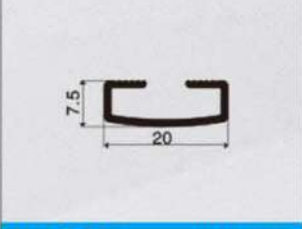
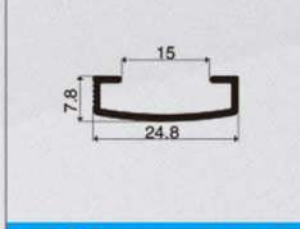
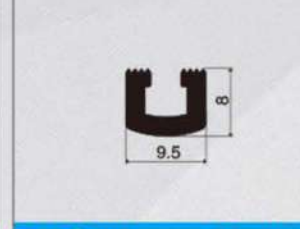
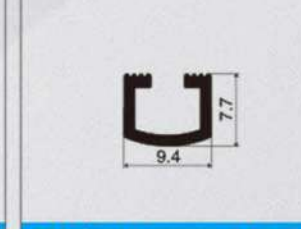
# LISTELLO TRIM

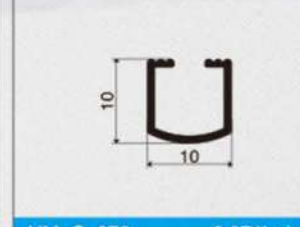
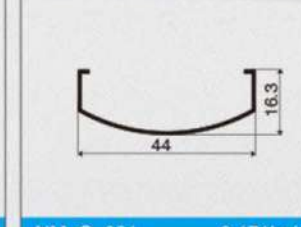
 HM-C-045 0.035kg/m	 HM-C-046 0.119kg/m	 HM-C-059 0.11kg/m	 HM-C-060 0.09kg/m
 HM-C-062 0.096kg/m	 HM-C-064 0.107kg/m	 HM-C-065 0.067kg/m	 HM-C-074 0.088kg/m
 HM-C-075 0.102kg/m	 HM-C-076 0.117kg/m	 HM-C-080 0.085kg/m	 HM-C-081 0.113kg/m
 HM-C-082 0.086kg/m	 HM-C-084 0.071kg/m	 HM-C-086 0.048kg/m	 HM-C-004 0.083kg/m
 HM-C-006 0.134kg/m	 HM-C-007 0.139kg/m	 HM-C-015 0.128kg/m	 HM-C-016 0.08kg/m
 HM-C-050 0.114kg/m	 HM-C-067 0.085kg/m	 HM-C-073 0.074kg/m	 HM-C-031 0.171kg/m

53

# LISTELLO TRIM

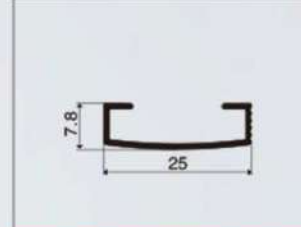
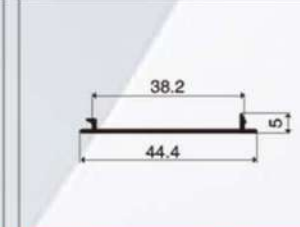
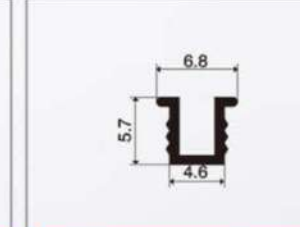
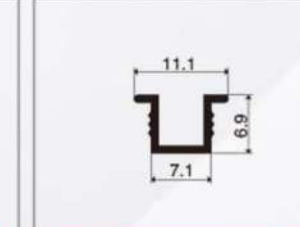
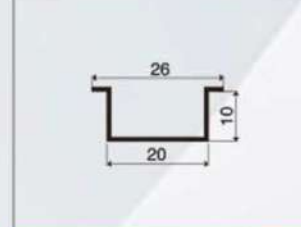
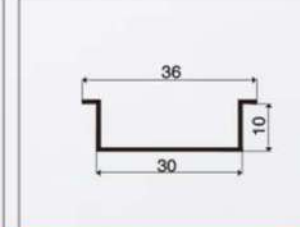
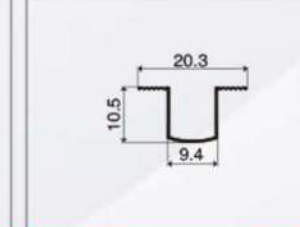
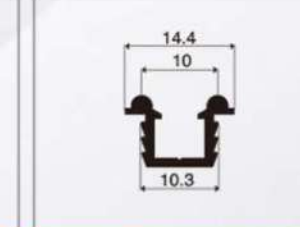
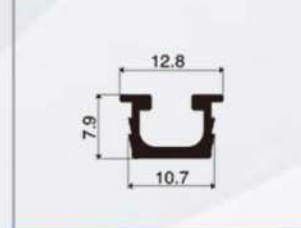
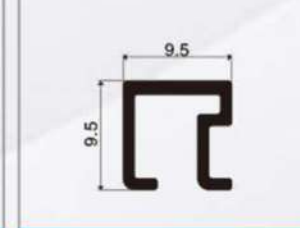
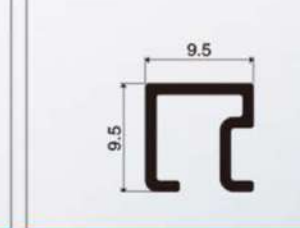
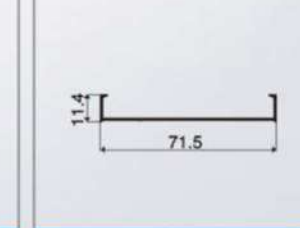
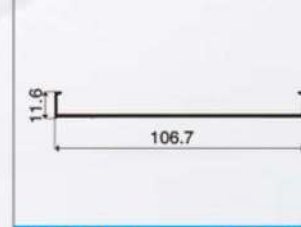
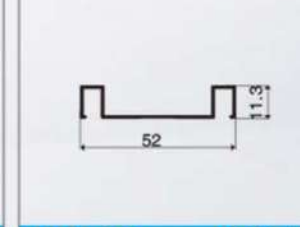
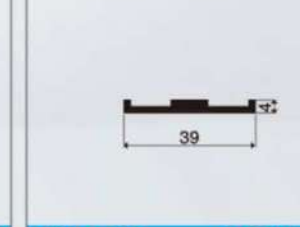
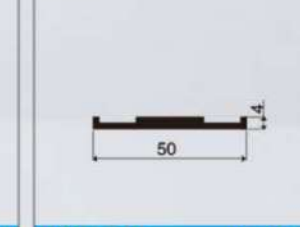
 HM-C-054 0.12kg/m	 HM-C-032 0.142kg/m	 HM-C-010 0.038kg/m	 HM-C-011 0.059kg/m
 HM-C-052 0.1kg/m	 HM-C-053 0.122kg/m	 HM-C-055 0.056kg/m	 HM-C-008 0.12kg/m
 HM-C-029 0.101kg/m	 HM-C-009 0.092kg/m	 HM-C-035 0.082kg/m	 HM-C-026 0.246kg/m
 HM-C-027 0.39kg/m	 HM-C-038 0.255kg/m	 HM-C-047 0.293kg/m	 HM-C-048 0.413kg/m

54

## Y-ANGLE TRIM

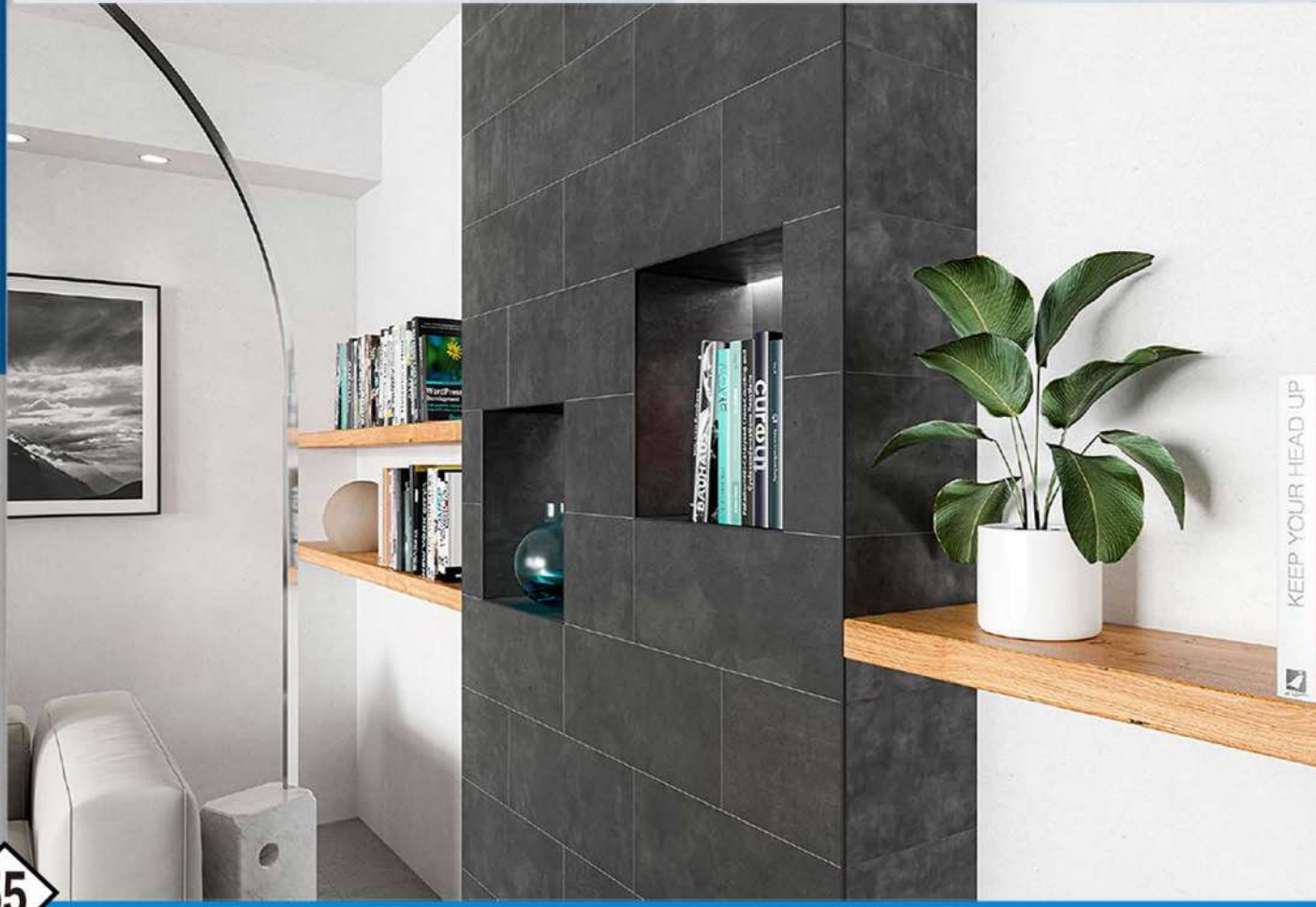

55

## Y-ANGLE TRIM

**Y-ANGLE TRIM** is a unique tile edging profile featuring a distinctive Y configuration, crafted to seamlessly merge three tiled surfaces. Its advantages include providing a visually appealing transition, protecting edges against damage and offering a contemporary touch to tiled spaces. Ideal for modern interiors, the Y-shaped trim finds application in kitchens, bathrooms and other areas where a sophisticated, geometric design element is desired.

### Application



## Y-ANGLE TRIM

EXEMPLES OF LAYING (for laying instructions, see Prokerlam square)

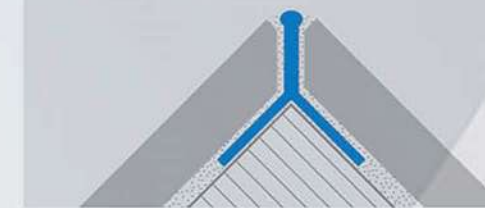

Y-ANGLE TRIM line is a new product conceived and designed with an almost invisible thin profile in order to reduce separation of the material to a minimum, for laying thin ceramic tiles; Keriflex/Laminam, and for mosaic. The notching created at the ends of the profiles allows the glue / adhesive to anchor perfectly to the profile. It protects the corner creating a technical-chromatic effect that is of great aesthetic value. Available in these colours AA - ANODISED SILVER aluminium, BC - Chromed polished aluminium, e BO - Gold polished aluminium.

### COLOUR

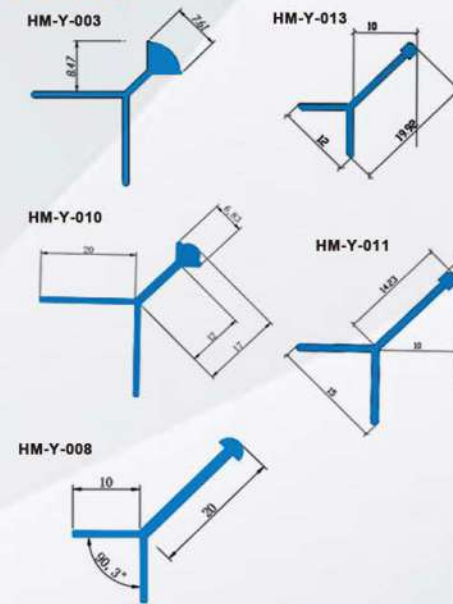

CODE	HIGHT/MM	WEIGHT KG/M
HM-Y-003	8.47	0.155
HM-Y-011	10	0.098
HM-Y-013	10	0.086
HM-Y-010	17	0.217
HM-Y-008	18	0.146

## Y-ANGLE TRIM

### Application



### Installation procedure



56

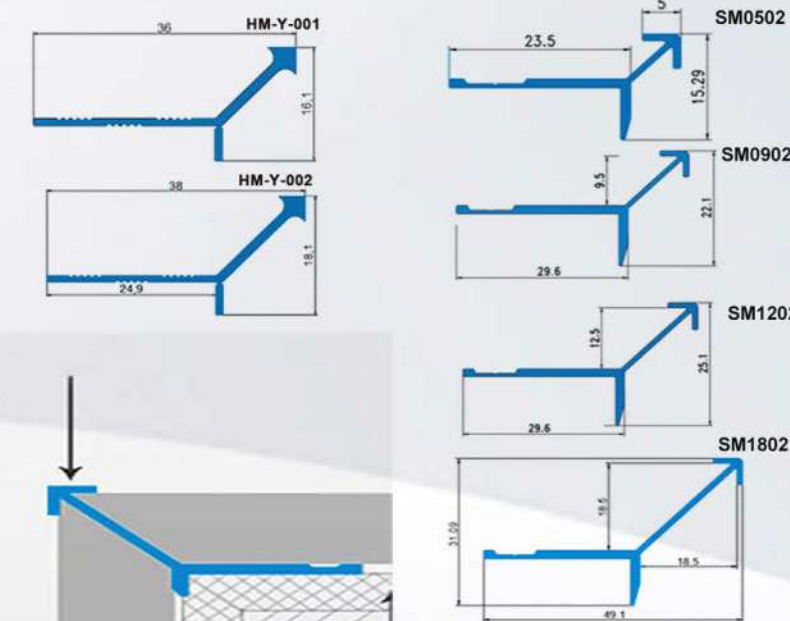

### EXAMPLES AND INSTRUCTIONS FOR LAYING METHODS



CODE	HIGHT/MM	WEIGHT KG/M
SM0502	5.5	0.132
LV-QB0802	8.3	0.199
SM0902	9.5	0.2
HM-Y-001	10	0.14
HM-Y-002	12	0.15
SM1202	12.5	0.217
SM1802	18.5	0.252



## CORNER EDGE TRIM



57

## CORNER EDGE

**CORNER EDGE TRIM** is a versatile edging profile used mainly in tile installations. It provides a protective and aesthetic edge finish, enhancing the longevity of tiled surfaces. Its advantages include ease of installation, durability and the ability to seamlessly blend with various tile designs, making it an ideal choice for both residential and commercial projects.



1. Choose the Corner edge L trim with suitable width for the thickness of the covering. 2. Apply the adhesive onto the area of application of the profile. 3. Lay and align the profile, cut to the necessary length, pressing the perforated flange into the adhesive. 4. Lay the tiles, aligning them so that the top edge of the profile is flush with the tile. 5. Fill the profile/tile area of contact with adhesive to prevent the accumulation of water in any voids.

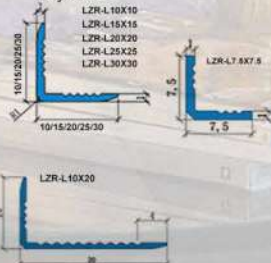

CODE	HIGHT/MM	WEIGHT KG/M
LZR-L7.5X7.5	7.5x7.5	0.034
LZR-L10X10	10x10	0.044
LZR-L15X15	15x15	0.068
LZR-L20X10	20x10	0.056
LZR-L20X20	20x20	0.091
LZR-L25X25	25x25	0.114
LZR-L30X30	30x30	0.137



## CORNER EDGE

EXAMPLES AND INSTRUCTIONS FOR LAYING METHODS



1. Choose the Corner edge L trim with suitable width for the thickness of the covering. 2. Apply the adhesive onto the area of application of the profile. 3. Lay and align the profile, cut to the necessary length, pressing the perforated flange into the adhesive. 4. Lay the tiles, aligning them so that the top edge of the profile is flush with the tile. 5. Fill the profile/tile area of contact with adhesive to prevent the accumulation of water in any voids.

### COLOUR

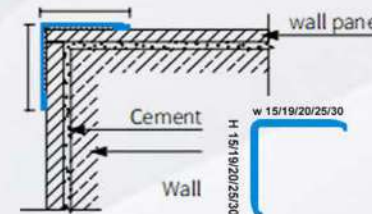

CODE	HIGHT/MM	WEIGHT KG/M
SMR-15x15	15x15	0.059
SMR-19x19	19x19	0.144
SMR-20x20	20x20	0.078
SMR-25x25	25x25	0.097
SMR-30x30	30x30	0.155



## CORNER EDGE TRIM

### Application



### Installation procedure



CODE	HIGHT/MM	WEIGHT KG/M
HM-L-257	15x15	0.062
HM-L-258	20x20	0.084
HM-L-259	25x25	0.106
HM-L-260	30x30	0.127



1. Choose the Corner edge L trim with suitable width for the thickness of the covering. 2. Apply the adhesive onto the area of application of the profile. 3. Lay and align the profile, cut to the necessary length, pressing the perforated flange into the adhesive. 4. Lay the tiles, aligning them so that the top edge of the profile is flush with the tile. 5. Fill the profile/tile area of contact with adhesive to prevent the accumulation of water in any voids.

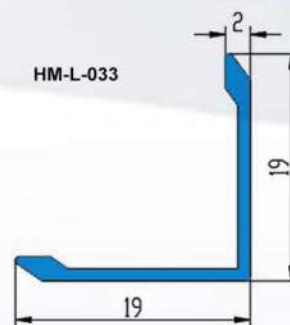
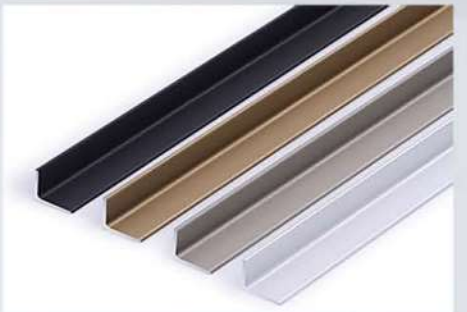

CODE	HIGHT/MM	WEIGHT KG/M
HM-L-241	10x10	0.054
HM-L-242	15x15	0.080
HM-L-128	16x16	0.100
HM-L-033	19x19	0.110
HM-L-034	25x25	0.138
HM-L-212	30x30	0.127
HM-L-218	35x35	0.192



58



# EXTERNAL CORNER TRIM

59

## EXTERNAL CORNER TRIM

EXTERNAL CORNER TRIM is a tile edging profile crafted to elegantly cover and protect external corners of tiled surfaces. Its advantages lie in providing a smooth, finished appearance while safeguarding corners from impact and wear. Widely utilized in kitchens, bathrooms and architectural projects, external angle trim ensures both aesthetic cohesion and durability in areas where tiles meet external angles.

### Application



## CORNER TRIM

EXAMPLES AND INSTRUCTIONS FOR LAYING METHODS

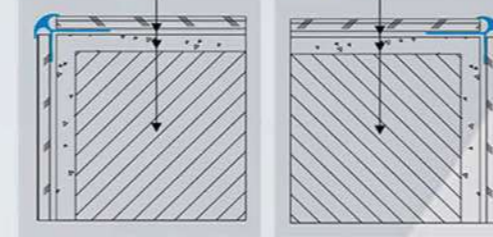

1. Choose the External Corner Trim with suitable width for the thickness of the covering. 2. Apply the adhesive onto the area of application of the profile. 3. Lay and align the profile, cut to the necessary length, pressing the perforated flange into the adhesive. 4. Lay the tiles, aligning them so that the top edge of the profile is flush with the tile. 5. Fill the profile/tile area of contact with adhesive to prevent the accumulation of water in any voids.

### COLOUR



CODE	HIGHT/MM	WEIGHT KG/M
SM0403	4	0.090
SM0703	7	0.112
SM0803	8.4	0.139
SM0803	12.1	0.261

### Installation procedure

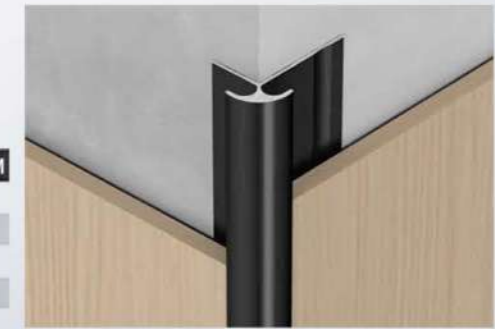

60

EXAMPLES AND INSTRUCTIONS FOR LAYING METHODS

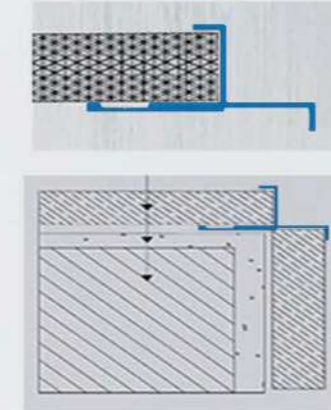
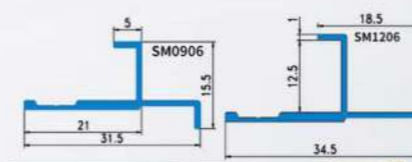

CODE	HIGHT/MM	WEIGHT KG/M
SM1206	12.5	0.160
SM0906	9.5	0.146

1. Choose the External Corner Trim with suitable width for the thickness of the covering. 2. Apply the adhesive onto the area of application of the profile. 3. Lay and align the profile, cut to the necessary length, pressing the perforated flange into the adhesive. 4. Lay the tiles, aligning them so that the top edge of the profile is flush with the tile. 5. Fill the profile/tile area of contact with adhesive to prevent the accumulation of water in any voids.



INTERNAL CORNER TRIM

# INTERNAL CORNER TRIM



61

# Internal Corner Trim

INTERNAL CORNER TRIM is a specialized tile edging profile crafted for neatly finishing internal corners in tiling projects. Its advantages include safeguarding vulnerable edges, preventing wear and tear and ensuring a cohesive appearance. Widely utilized in kitchens, bathrooms and architectural designs, internal angle trim offers both functional protection and aesthetic continuity, creating a polished look at corners where tiles converge in interior spaces

Application



# Internal Corner Trim

INTERNAL CORNER TRIM

EXAMPLES AND INSTRUCTIONS FOR LAYING METHODS

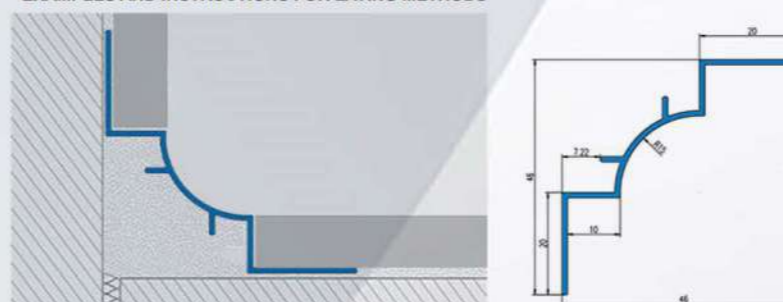

Code	D (mm)	Weight (kg/m)
HM-R-049	46	0.251

1. Choose the INTERNAL CORNER TRIM with suitable height for the thickness of the covering/floor. 2. Apply the adhesive onto the area of application of the profile. 3. Lay and align the profile, cut to the necessary length, pressing the perforated flange into the adhesive. 4. Lay the tiles, aligning them so that the top edge of the profile is flush with the tile and also joints, linking elements, etc. 5. Fill the profile/tile area of contact with adhesive to prevent the accumulation of water in any voids. Before laying the floor/wall covering, fix the profiles/joints to ensure perfect results.

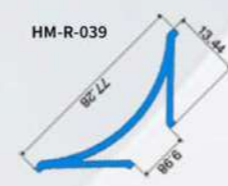

Code	D (mm)	Weight (kg/m)
HM-R-039	13.44	0.217
HM-R-065	12.40	0.190

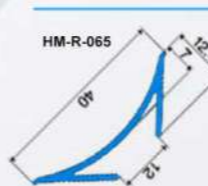

Code	D (mm)	Weight (kg/m)
DCA400	40x40	0.192



Code	D (mm)	Weight (kg/m)
CZ017	17x17	0.100

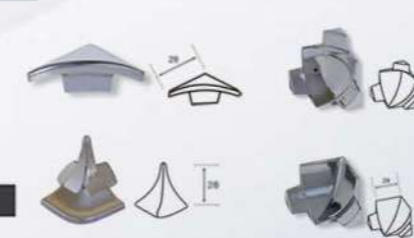

62

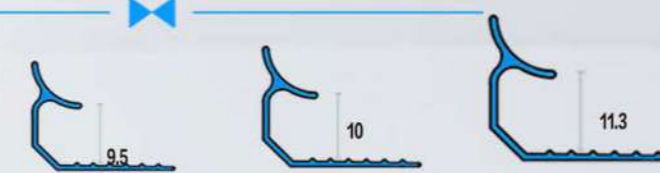

Code	D (mm)	Weight (kg/m)
HM-MI4362	11.3	0.121
HM-MI4658	10	0.150
HM-MI4301	9	0.135

ACCESSORIES

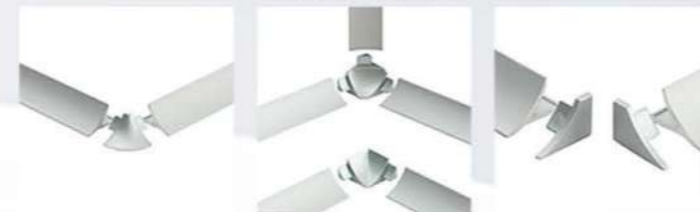

Code	W (mm)	Weight (kg/m)
HM-RH-TCA-220	22	0.122
HM-RH-TCA-160	16	0.096
HM-RH-TCA-120	12	0.069



H JOINT TRIM



# H JOINT TRIM

63

## H JOINT TRIM

H JOINT TRIM is a specialized tile edging profile characterized by its dual-leg design resembling the letter "H." This versatile trim offers a sleek transition between tiles, ensuring a neat and polished appearance while providing protection to vulnerable edges. Ideal for various applications, H Joint Trim is commonly used in kitchens, bathrooms and other high-traffic areas, ensuring both durability and a polished finish in tiled spaces.

Application



## H JOINT TRIM

EXAMPLES AND INSTRUCTIONS FOR LAYING METHODS

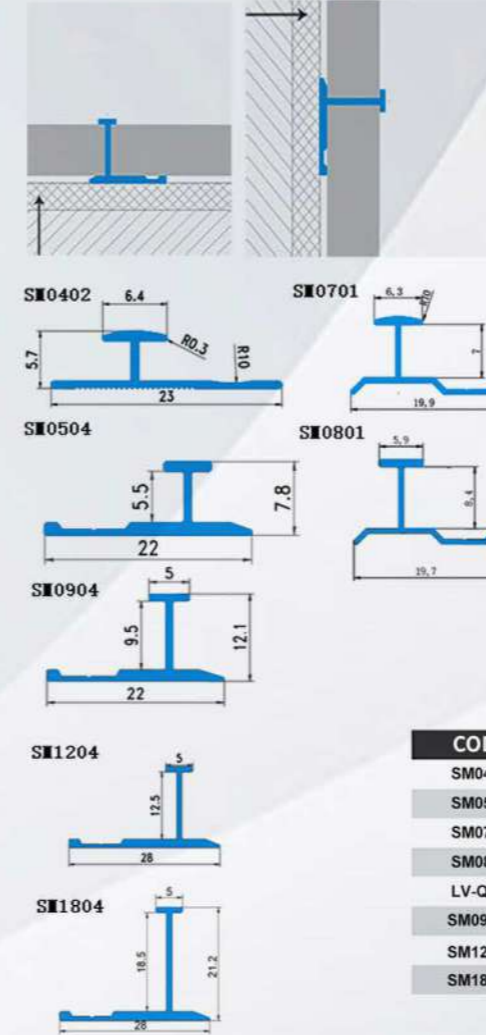

CODE	HIGHT/MM	WEIGHT KG/M
SM0402	4	0.061
SM0504	5.5	0.086
SM0701	7	0.061
SM0801	8.4	0.064
LV-QB-0804	8.3	0.121
SM0904	9.5	0.109
SM1204	12.5	0.142
SM1804	18.5	0.168

Installation procedure



64

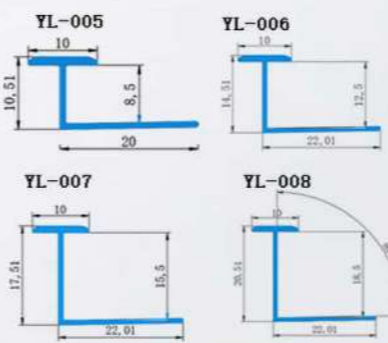

EXAMPLES AND INSTRUCTIONS FOR LAYING METHODS

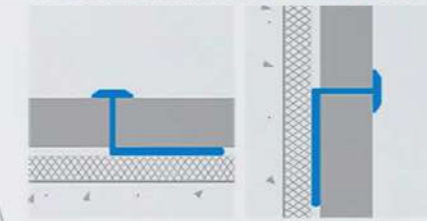

1. Choose the H JOINT TRIM with the width suitable for the gap between the two floors to be joined, taking into consideration 2/3 mm side lap. 2. Fill the gap with single-pack silicone or with the adhesive used for laying the floor. 3. Bury the profile into the adhesive, making sure that both side laps of the profile rest on the coverings to be joined. Profiles in natural or polished brass may be subject to oxidation in environments with high degrees of humidity. Resulting marks may be easily removed by polishing the profiles with specific products to be found on sale such as Sidol, Smac and similar.





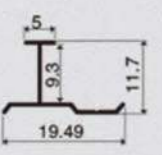
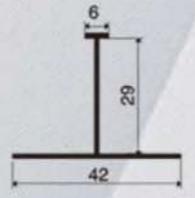
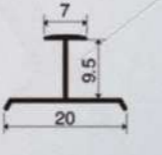
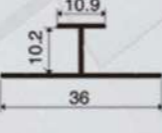
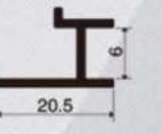
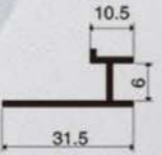
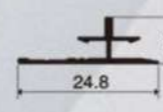
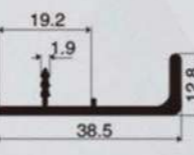
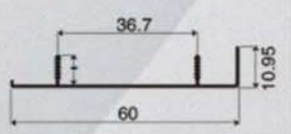
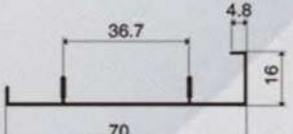
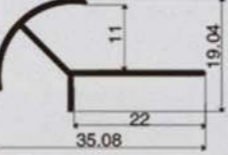
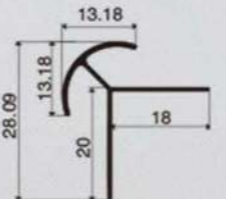
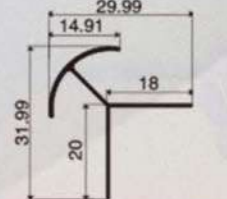
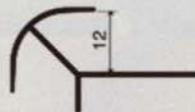
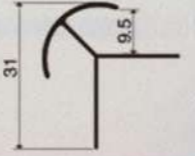
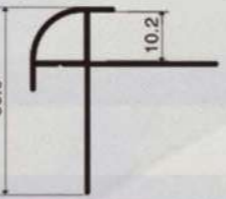
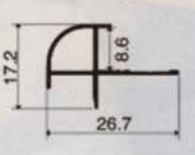
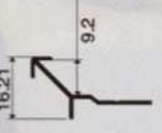
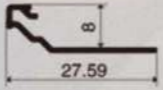
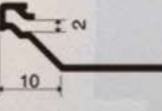
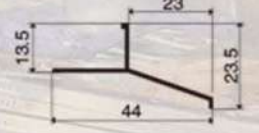
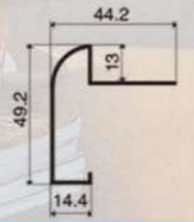
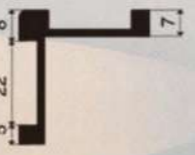
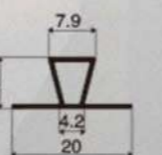

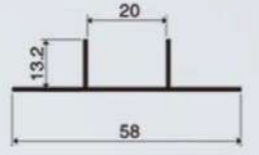
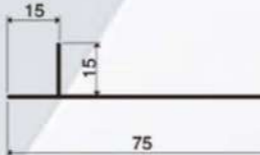

CODE	HIGHT/MM	WEIGHT KG/M
YL-005	8.5	0.092
YL-006	12.5	0.105
YL-007	15.5	0.112
YL-008	18.5	0.118

# PANEL PROFILE

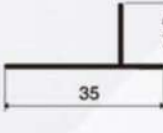
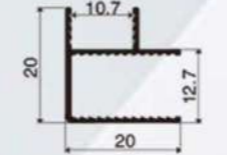
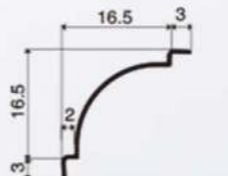
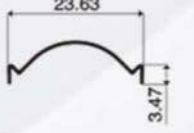
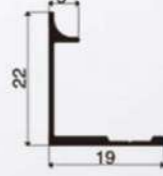
 HM-P-069 0.057kg/m	 HM-P-105 0.233kg/m	 HM-P-116 0.078kg/m	 HM-P-120 0.154kg/m
 HM-P-131 0.171kg/m	 HM-P-132 0.216kg/m	 HM-P-136 0.102kg/m	 HM-P-009 0.297kg/m
 HM-P-071 0.184kg/m	 HM-P-074 0.243kg/m	 HM-P-029 0.163kg/m	 HM-P-031 0.137kg/m
 HM-P-032 0.150kg/m	 HM-P-110 0.172kg/m	 HM-P-115 0.155kg/m	 HM-P-118 0.289kg/m
 HM-P-135 0.134kg/m	 HM-P-080 0.129kg/m	 HM-P-092 0.107kg/m	 HM-P-097 0.108kg/m
 HM-P-039 0.167kg/m	 HM-P-123 0.376kg/m	 HM-P-064 0.599kg/m	 HM-P-027 0.083kg/m

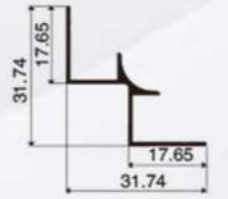
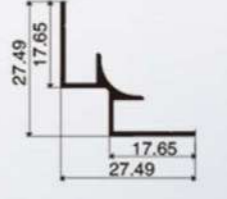
65

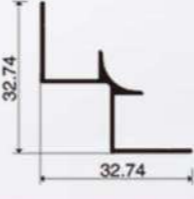
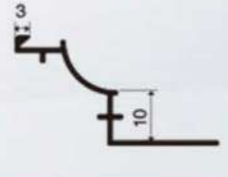
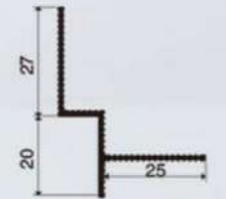
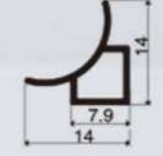
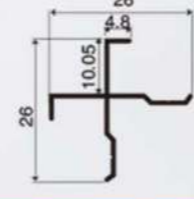
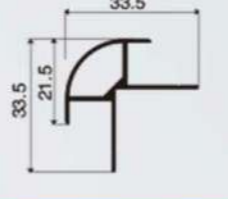
# PANEL PROFILE

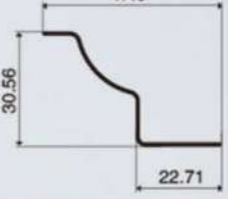
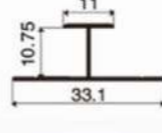
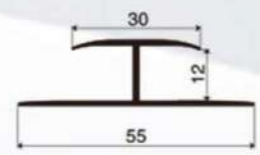
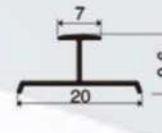
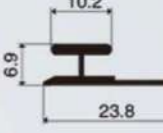
 HM-P-049 0.224kg/m	 HM-P-078 0.224kg/m	 HM-P-079 0.119kg/m	 HM-P-089 0.132kg/m
 HM-P-005 0.150kg/m	 HM-P-034 0.053kg/m	 HM-P-035 0.046kg/m	 HM-P-067 0.120kg/m
 HM-P-086 0.105kg/m	 HM-P-004 0.185kg/m	 HM-P-004 -2 0.165kg/m	 HM-P-119 0.223kg/m
 HM-P-127 0.189kg/m	 HM-P-093 0.176kg/m	 HM-P-133 0.285kg/m	 HM-P-026 0.084kg/m
 HM-P-070 0.124kg/m	 HM-P-002 0.254kg/m	 HM-R-015 0.289kg/m	 HM-R-108 0.17kg/m
 HM-P-003 0.115kg/m	 HM-P-022 0.318kg/m	 HM-P-030 0.068kg/m	 HM-P-050 0.131kg/m

66

SHOWER PROFILE

# SHOWER PROFILE



## SHOWER PROFILE

Shower Profile is a purpose-built trim designed for wet environments, providing a protective and aesthetic edge to tiles. Its advantages include moisture resistance, preventing water damage and contributing to a cohesive bathroom design. Widely used in shower enclosures, bathtub surrounds and backslashes, bathroom profiles offer both functionality and style, ensuring a durable and visually appealing finish in areas prone to water exposure.

67

EXAMPLES AND INSTRUCTIONS FOR LAYING METHODS

CODE	HIGHT/MM	WEIGHT KG/M
HM-F054	10*12	0.147
HM-F032	14*12	0.164

### Product Installation Diagram



COUNTERTOP PROFILE

# COUNTERTOP PROFILE

Connector



Cabinets Trim protects the edges, hiding or covering gaps between joining edges of different materials, applied similar protect the joint ensuring an elegant transition.

Apply to customize.

Material	Aluminum
Shape	Multiform
Thickness	To order



68

# TRANSITIONS FLOORING PROFILE



69

## Transitions flooring profile

**TRANSITION PROFILES** are versatile tile edging solutions designed to seamlessly connect different flooring surfaces, providing a smooth and polished transition. Its advantages include preventing edge damage, ensuring a cohesive look and accommodating height variations between surfaces. Widely used in doorways, between rooms and where various flooring materials meet, transition profiles offer a practical and aesthetic solution.

### Application



## Transitions flooring profile

### EXAMPLES AND INSTRUCTIONS FOR LAYING METHODS

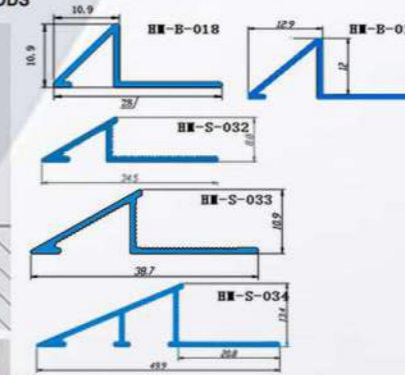

CODE	HIGHT/MM	WEIGHT KG/M
HM-S-032	7.8	0.123
HM-B-018	10	0.108
HM-S-033	9.9	0.138
HM-S-019	12	0.120
HM-S-034	12.4	0.203

1. Choose the profile with the required height H, material and finish. 2. Fill the profile cavity with adhesive and apply the adhesive onto the area of application. 3. Lay the profile. 4. Align it "flush" with the floor covering. 5. Use the adhesive to seal any empty interstices. Oxidation marks on profiles in natural and polished brass may be easily removed by polishing the profiles with specific products to be found on sale such as Sidol, Smac and similar.

### EXAMPLES AND INSTRUCTIONS FOR LAYING METHODS

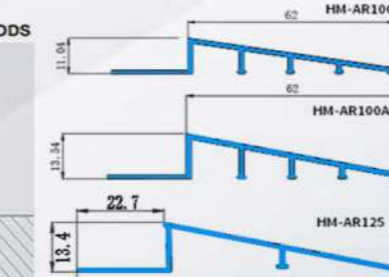
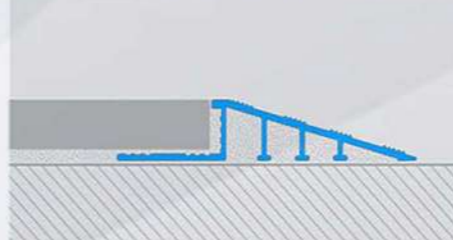

CODE	HIGHT/MM	WEIGHT KG/M
HM-AR100	10	0.390
HM-AR100A	12.5	0.397
HM-AR1125	12.5	0.345
HM-AR1125	12.4	0.292
HM-AR1126	12.5	0.419

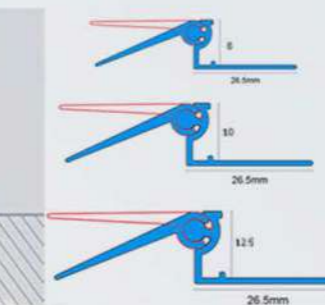
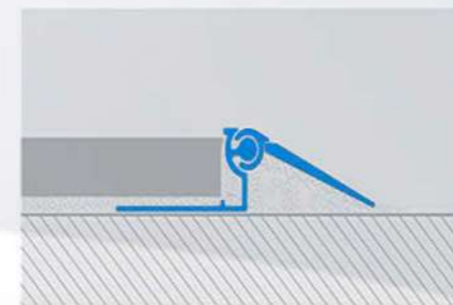
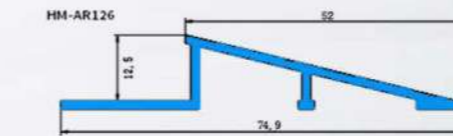

CODE	HIGHT/MM	WEIGHT KG/M
HM-AP8	8	0.125
HM-AP10	10	0.136
HM-AP125	12.5	0.150

1. Choose the profile with the required height H, material and finish. 2. Fill the profile cavity with adhesive and apply the adhesive onto the area of application. 3. Lay the profile. 4. Align it "flush" with the floor covering. 5. Use the adhesive to seal any empty interstices. Oxidation marks on profiles in natural and polished brass may be easily removed by polishing the profiles with specific products to be found on sale such as Sidol, Smac and similar.

70

## TRANSITIONS FLOORING PROFILE



### TRANSITIONS FLOORING PROFILE

Application

71

TRANSITIONS FLOORING PROFILE are versatile tile edging solutions designed to seamlessly connect different flooring surfaces, providing a smooth and polished transition. Its advantages include preventing edge damage, ensuring a cohesive look and accommodating height variations between surfaces. Widely used in doorways, between rooms and where various flooring materials meet, transition profiles offer a practical and aesthetic solution.

CODE	HIGHT/MM	WEIGHT KG/M
HM-016	3.3	0.203
HM-043	4	0.0498

1. Choose PROFILE with or without sticker and cut it to the required length. 2. Degrease, wash and clean accurately the solid floor. 3. Remove the protective label from the sticker (sticker model). 4. Rest the square pressing evenly without hammering. 5b. Perforate on one side and insert the nogs in the holes. 5. Fix and screw the square equipped with flared head screws suitable to the holes made.

ANODISED ALUMINIUM WITH ADHESIVE thermo packed  
bar length 2,7 LM - pack. 40 Pcs - 108 LM

CODE	HIGHT/MM	WEIGHT KG/M
HM-039	4	0.169

## TRANSITIONS FLOORING PROFILE



Application

Adhesive version  
1. Choose the suitable profile and cut it to the necessary length.  
2. Degrease, wash and clean the solid surface thoroughly. 3. Remove the protective paper from the adhesive. 4. Lay the profile by applying pressure evenly over the whole surface without using a hammer.  
Punched version  
1. Choose the suitable profile and cut it to the necessary length.  
2. Mark the position of the holes using the existing holes in the profile

CODE	H MM	KG/M
HM-F-089	4	0.168
HM-F-094	4	0.182

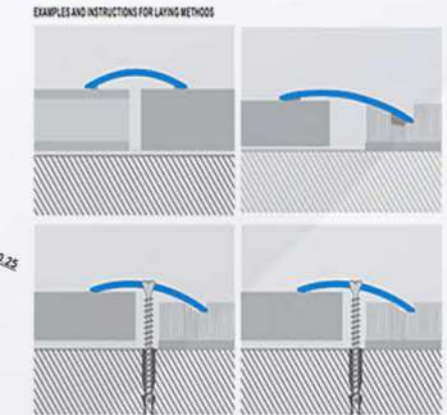

EXAMPLES AND INSTRUCTIONS FOR LAYING METHODS



1. Choose the Transitions flooring profile in the required finish. 2. Cut the profile to the required length and clean, degrease and dry the surface, checking that the temperature for application is at least 15°. 3. Remove the protective paper from the adhesive and lay the profile correctly applying a uniform vertical pressure by hand without moving the profile and without using iron/steel hammers.

EXAMPLES AND INSTRUCTIONS FOR LAYING METHODS



EXAMPLES AND INSTRUCTIONS FOR LAYING METHODS

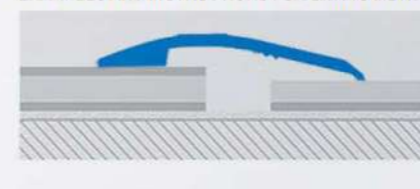

EXAMPLES OF LAYING

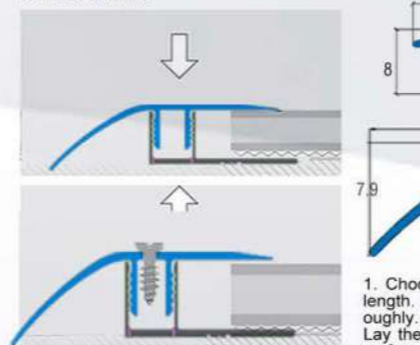

1. Choose the suitable profile and cut it to the necessary length. 2. Degrease, wash and clean the solid surface thoroughly. 3. Remove the protective paper from the adhesive. 4. Lay the profile by applying pressure evenly over the whole surface without using a hammer.

CODE	HIGHT/MM	WEIGHT KG/M
HM-011	8	0.161
HM-012	8	0.149
HM-024	9	0.105

72



# TRANSITIONS FLOORING PROFILE

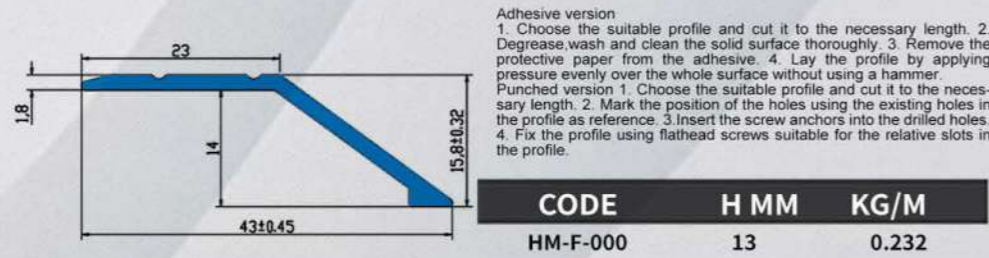

**Adhesive version**  
 1. Choose the suitable profile and cut it to the necessary length. 2. Degrease, wash and clean the solid surface thoroughly. 3. Remove the protective paper from the adhesive. 4. Lay the profile by applying pressure evenly over the whole surface without using a hammer.  
**Punched version**  
 1. Choose the suitable profile and cut it to the necessary length. 2. Mark the position of the holes using the existing holes in the profile as reference. 3. Insert the screw anchors into the drilled holes. 4. Fix the profile using flathead screws suitable for the relative slots in the profile.

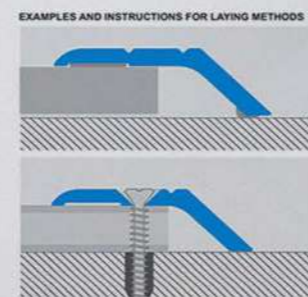

73



**EXAMPLES AND INSTRUCTIONS FOR LAYING METHODS**

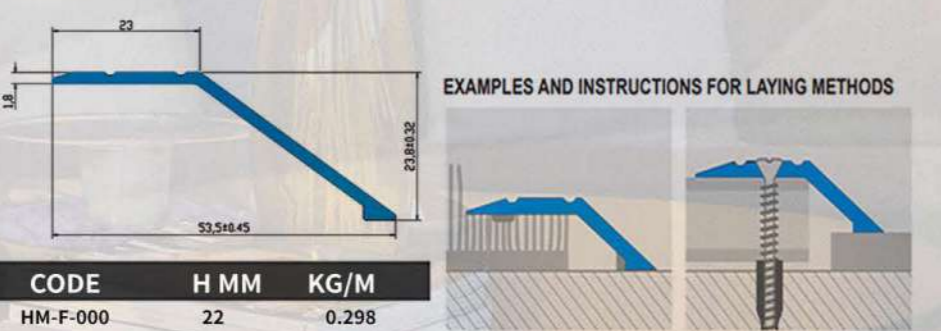

**EXAMPLES AND INSTRUCTIONS FOR LAYING METHODS**



 HM-P-007 0.199kg/m	 HM-P-008 0.183kg/m	 HM-P-014 0.158kg/m	 HM-P-019 0.775kg/m
 HM-P-020 0.170kg/m	 HM-P-055 0.163kg/m	 HM-P-107 0.093kg/m	 HM-P-122 0.126kg/m
 HM-P-129 0.506kg/m	 HM-P-036 0.144kg/m	 HM-P-075 0.203kg/m	 HM-P-077 0.148kg/m
 HM-P-112 0.178kg/m	 HM-P-025 0.066kg/m	 HM-P-111 0.100kg/m	 HM-F-000 0.298KG/M
 HM-F-000 0.298KG/M	 HM-F-093 0.167KG/M	 HM-F-011 0.161KG/M	 HM-F-000 0.137KG/M
 HM-AR126 0.419KG/M	 HM-S-034 0.203KG/M	 HM-S-033 0.138KG/M	 HM-F-094 0.182KG/M

74

# CARPET PROFILE



75

## Carpet profile

**CARPET PROFILE** is a transition strip that joins carpeted and non-carpeted floors seamlessly. Its key advantage lies in providing a smooth and safe transition, preventing tripping hazards and preserving the carpet's edge. This profile is widely used in doorways, hallways and areas where carpet meets hard flooring, ensuring a neat and secure junction while enhancing safety in both residential and commercial spaces

### Application



## Carpet profile

EXAMPLES AND INSTRUCTIONS FOR LAYING METHODS

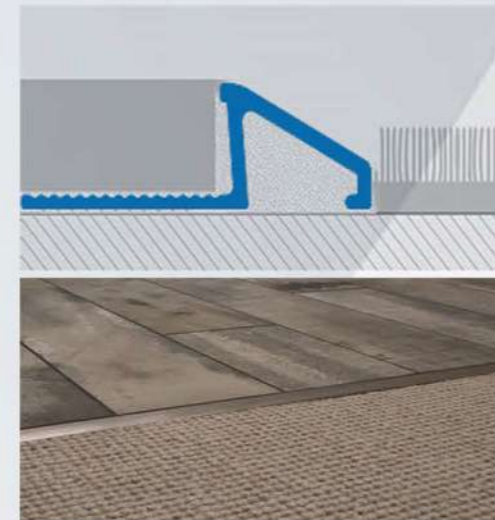

1. Choose the Carpet profile taking into consideration the exact height of the floor. 2. Using a notched spreader apply the adhesive onto the area of application of the profile. 3. Lay and align the profile, cut to the necessary length, pressing the perforated flange into the adhesive. 4. Lay the tiles, aligning them so that the top edge of the profile is "flush" with the tile. 5. Fill the profile/tile area of contact with adhesive to prevent the accumulation of water in any voids.

CODE	H MM	KG/M
HM-S-061	8	0.177
HM033	10	0.188
HM032	8	0.123



CODE	H MM	KG/M
HM-S-061	8	0.177
HM033	10	0.188
HM032	8	0.123

EXAMPLES AND INSTRUCTIONS FOR LAYING METHODS



CODE	H MM	WEIGHT KG/M
HM-F-068	8.3	0.075
HM-F-075	10	0.131
HM-F-041	10	0.141
HM-F-017	12	0.150



CODE	H MM	WEIGHT KG/M
HM-F-068	8.3	0.075
HM-F-075	10	0.131
HM-F-041	10	0.141
HM-F-017	12	0.150

EXAMPLES AND INSTRUCTIONS FOR LAYING METHODS

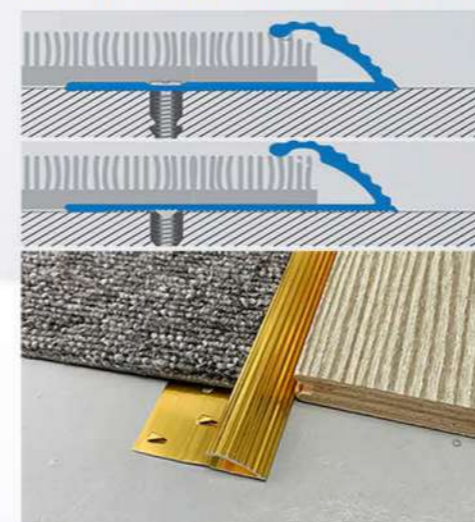

CODE	HIGHT/MM	WEIGHT KG/M
HM-F-001	8.26	0.156
HM-F-061	8.31	0.130
HM-F-076	9.20	0.148
HM-F-085	9.46	0.133
HM-F-049	10.48	0.157
HM-F-034	11.5	0.132
HM-F-017	11.71	0.15
HM-F-091	12	0.171
HM-F-000	10	0.128
HM-F-000	16	0.178

76

# Carpet profile

## EXAMPLES AND INSTRUCTIONS FOR LAYING METHODS

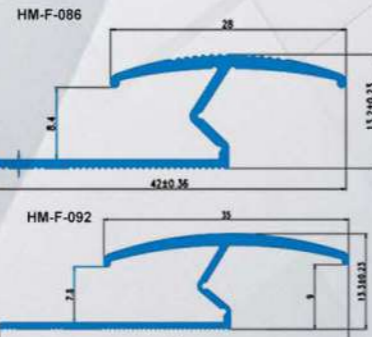
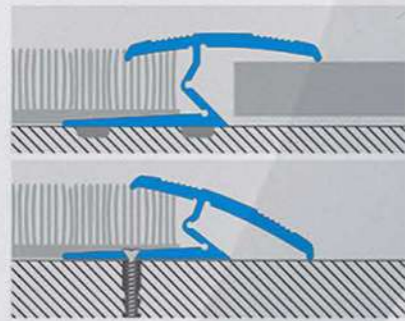

1. Cut the profile to the necessary length.
2. Fix the CARPET PROFILE to the floor using screws/nails or two-sided adhesive tape.
3. Lay the required floor, inserting the carpeting, PVC, linoleum, ceramic tile or wood under the upper curved part.
4. Apply pressure evenly on the edges of the profile until they close and secure the flooring on both sides.

CODE	W*H MM	KG/M
HM-F-007	19*17	0.155
HM-F-086	28*13	0.196
HM-F-092	35*13	0.237

## EXAMPLES AND INSTRUCTIONS FOR LAYING METHODS

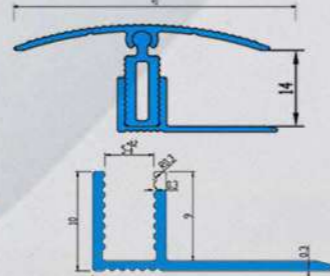
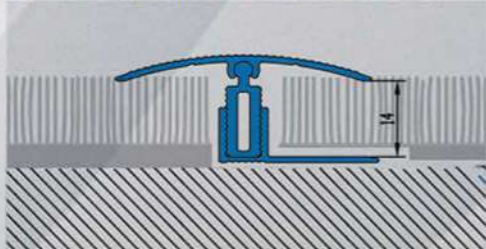

1. Cut the profile to the necessary length.
2. Fix the punched/notched base to the floor using screws/nails or two-sided adhesive tape.
3. Lay the carpeting by gluing or holding under tension.
4. With the help of a wooden tapping block and a hammer, apply pressure evenly over the hole of the top profile until it clicks into the base, thereby securing the carpeting on both sides.

CODE	W*H MM	KG/M
HM-MI4242	25*10	0.12
HM-MI4474	40*4.7	0.137

## EXAMPLES AND INSTRUCTIONS FOR LAYING METHODS

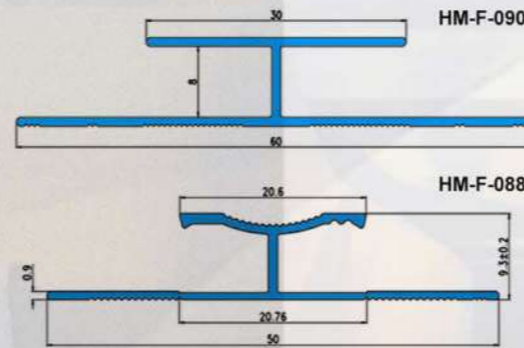
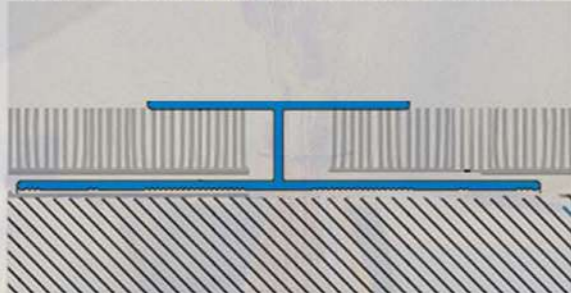

CODE	W*H MM	KG/M
HM-F-090	60*8	0.181
HM-F-088	50*9	0.257

1. Cut the profile to the necessary length.
2. Fix the punched/notched base to the floor using screws/nails or two-sided adhesive tape.
3. Lay the carpeting by gluing or holding under tension.
4. With the help of a wooden tapping block and a hammer, apply pressure evenly over the hole of the top profile until it clicks into the base, thereby securing the carpeting on both sides.

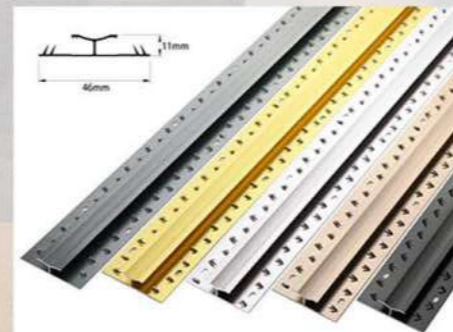

# CARPET PROFILE

 HM-AR-03 0.155kg/m	 HM-F-007 0.155kg/m	 HM-F-010 0.16kg/m	 HM-F-033 0.233kg/m
 HM-F-042 0.18kg/m	 HM-F-086 0.196kg/m	 HM-F-092 0.237kg/m	 HM-F-104 0.177kg/m
 HM-F-105 0.145kg/m	 HM-F-106 0.139kg/m	 HYB-28.5X10.8 0.093kg/m	 HM-F-001 0.156kg/m
 HM-F-017 0.15kg/m	 HM-F-061 0.13kg/m	 HM-F-034 0.132kg/m	 HM-F-085 0.133kg/m
 HM-F-041 0.141kg/m	 HM-F-068 0.075kg/m	 HM-F-075 0.131kg/m	 HM-F-049 0.157kg/m
 HM-F-076 0.148kg/m	 HM-F-091 0.171kg/m	 HM-F-088 0.181kg/m	 HM-F-090 0.257kg/m



## FORMABLE TRIM

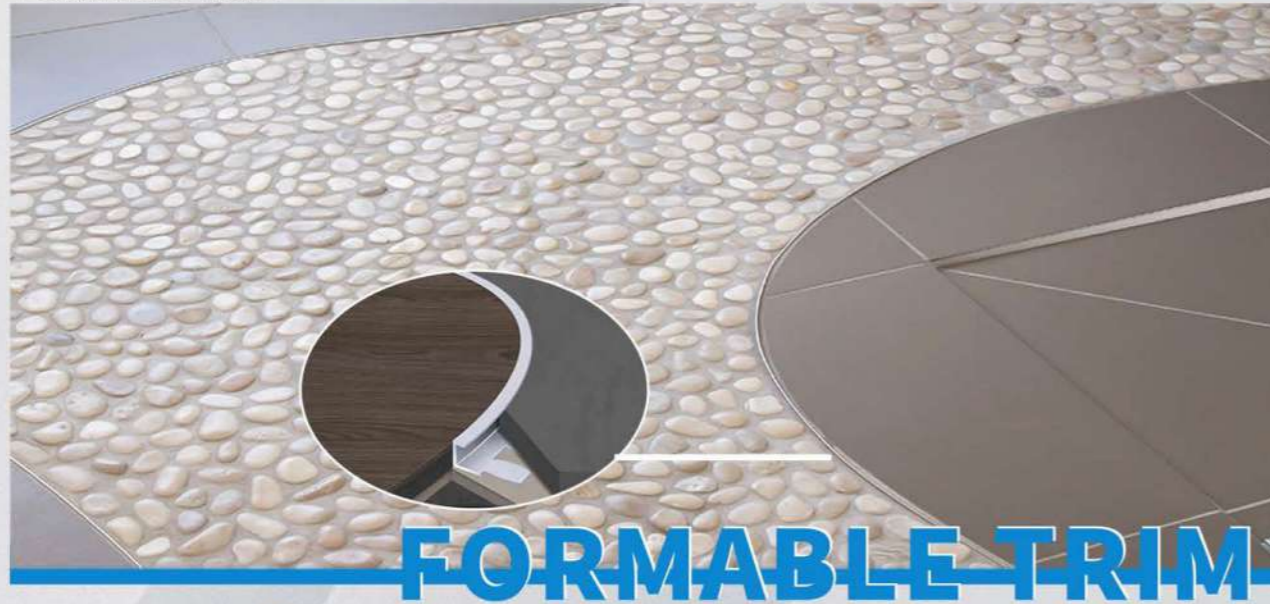

# FORMABLE TRIM

**FORMABLE TRIM** is a curved tile edging profile, featuring a graceful arc design that imparts a unique touch to tiled spaces. Its advantages include providing a smooth and elegant transition between different surfaces, preventing edge damage. Ideal for curved installations, such as shower surrounds or columns, Formable Trim offers versatility and durability, elevating the visual appeal and functionality of tiled areas with a touch of sophistication.

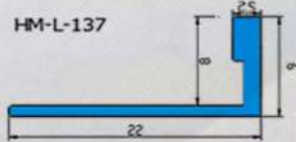
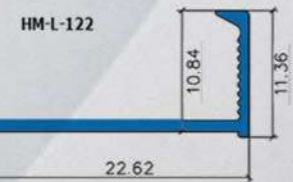
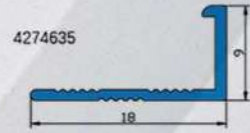

CODE	HIGHT/MM	WEIGHT KG/M
HM-L-122	9.84	0.09
4274635	8	0.07
HM-L-137	8	0.07

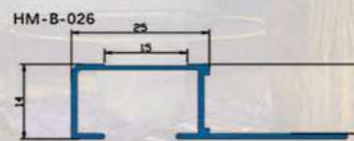
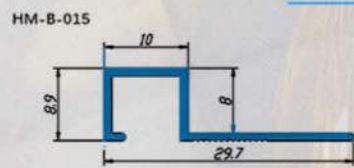

1. Choose the Formable Trim in the required height and material.
2. Cut the profile to the necessary length, calculating the total length.
3. Bend the profile mechanically with the profile.
4. If necessary fix with screws and screw anchors or simply insert the punched base under the floor laid with the same adhesive. Any oxidation marks may be easily removed with specific chemical products (Sidel-Smac, etc.).

### EXAMPLES AND INSTRUCTIONS FOR LAYING METHODS

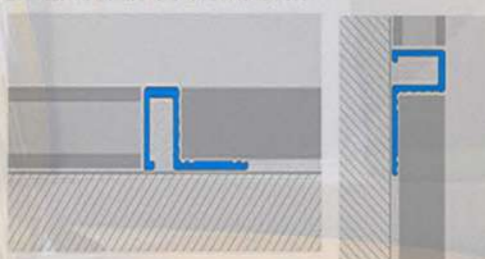

CODE	HIGHT/MM	WEIGHT KG/M
HM-B-015	8	0.112
HM-B-026	14	0.223



## FORMABLE TRIM

### EXAMPLES AND INSTRUCTIONS FOR LAYING METHODS

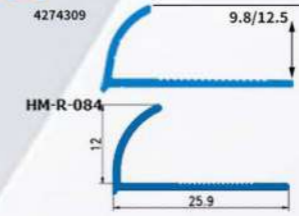
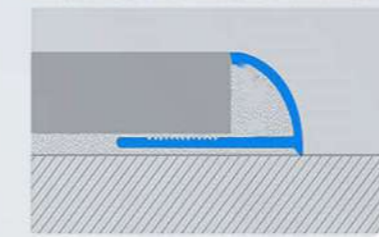

CODE	HIGHT/MM	WEIGHT KG/M
4274309	12.71	0.106
HM-R-084	12	0.105

1. Choose the Formable Trim in the required height and material.
2. Cut the profile to the necessary length, calculating the total length.
3. Bend the profile mechanically with the profile.
4. If necessary fix with screws and screw anchors or simply insert the punched base under the floor laid with the same adhesive.

## FORMABLE TRIM

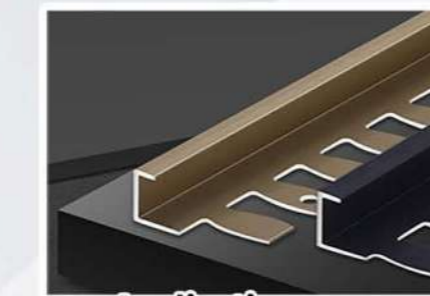

### Application

1. Choose the Formable Trim in the required height and material.
2. Cut the profile to the necessary length, calculating the total length.
3. Bend the profile mechanically with the Formable Trim.
4. If necessary fix with screws and screw anchors or simply insert the punched base under the floor laid with the same adhesive.

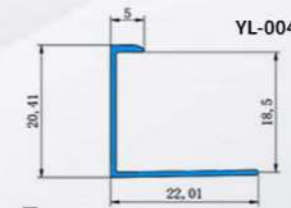
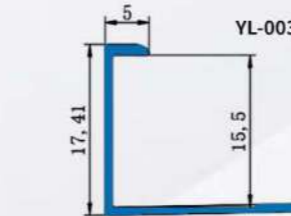

### EXAMPLES AND INSTRUCTIONS FOR LAYING METHODS

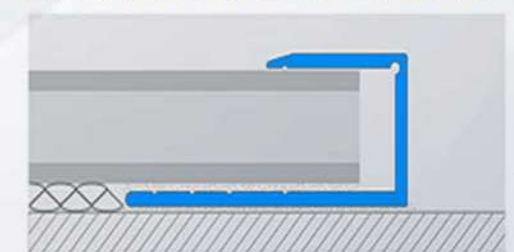

CODE	HIGHT/MM	WEIGHT KG/M
YL-003	15.5	0.095
YL-004	18.5	0.102

### EXAMPLES OF LAYING

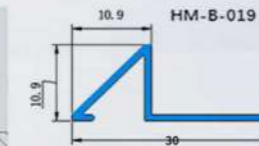

1. Choose the Formable Trim in the required finish.
2. Cut the profile to the required length and clean, degrease and dry the surface checking that the temperature for application is at least 15°.
3. Remove the protective paper from the adhesive and lay the profile correctly applying a uniform vertical pressure by hand without moving the profile and without using iron/steel hammers.

CODE	HIGHT/MM	WEIGHT KG/M
HM-B-019	12	0.12

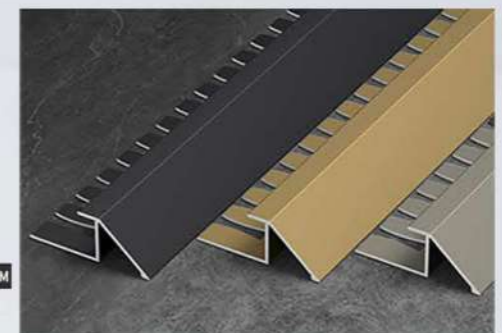

CODE	HIGHT/MM	WEIGHT KG/M
HM-T-069	8*20	0.067

### EXAMPLES AND INSTRUCTIONS FOR LAYING METHODS

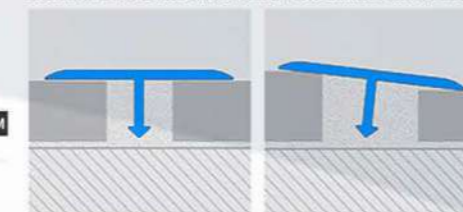

## MOVEMENT JOINTS



83

# Movement Joints

**MOVEMENT JOINTS**, also known as expansion joints, designed to absorb thermal expansion, seismic activity and settlement in structures. Its main advantage lies in preventing cracks and damage caused by structural movement, ensuring the integrity and longevity of buildings. These joints are commonly applied in large, concrete structures like bridges, highways and high-rise buildings, as well as in tiled surfaces.

### EXAMPLES AND INSTRUCTIONS FOR LAYING METHODS

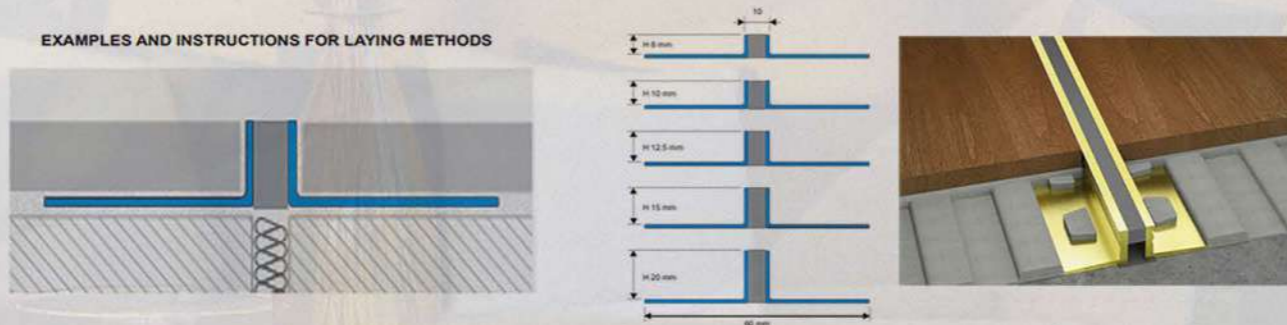

CODE	H mm
HM-H-001	8
HM-H-002	10
HM-H-003	12,5
HM-H-004	15
HM-H-005	20

## MOVEMENT JOINTS

### EXAMPLES AND INSTRUCTIONS FOR LAYING METHODS

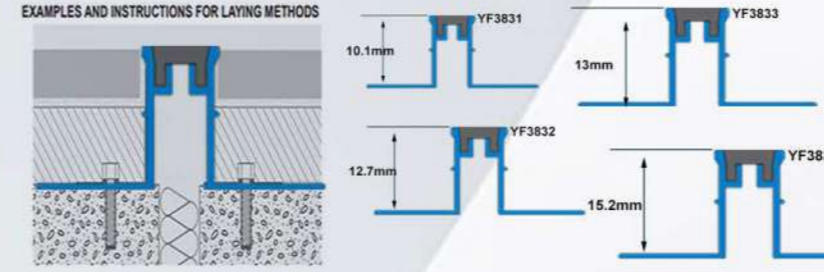

1. Choose the Movement Joints with suitable height for the thickness of the floor and the screed/floor rough and choose the colour of the insert. 2. Fix the punched flanges to the substrate using screws and screw anchors, calculating the fixing points at 30cm intervals on both sides. 3. Make the screed over the punched flanges of the structural or Movement Joints, calculating the thickness of the final floor, and then lay the floor as normal.

CODE	HIGHT/MM	WEIGHT KG/M
YF3831	10.2	0.133
YF3832	12.7	0.143
YF3835	13	0.145
YF3833	15.2	0.154
L-301	22	0.181
MJ-001	22.5	0.184

### EXAMPLES AND INSTRUCTIONS FOR LAYING METHODS

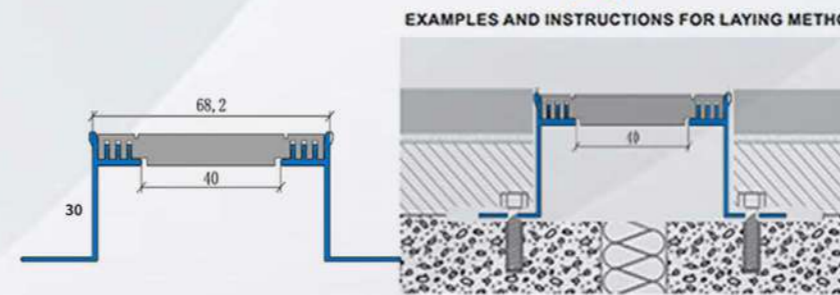

### EXAMPLES AND INSTRUCTIONS FOR LAYING METHODS

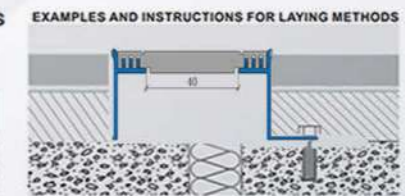

CODE	HIGHT/MM	WEIGHT KG/M
YF3834	30	0.27

### Application

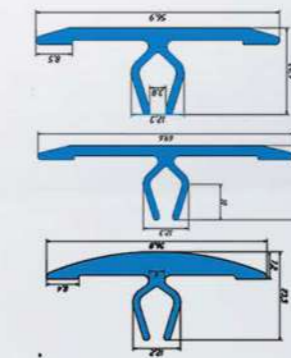

1. Choose the profile in the required width and material. 2. Insert the fixing clips into the relative groove (5 pcs. for wall applications - 10 pcs. for floor applications). 3. Insert/Lay the profile in the existing void, applying uniform pressure or using a plastic hammer, thereby creating a perfect joint cover. The same method is used for laying the corner profile.

CODE	HIGHT/MM	WEIGHT KG/M
HM-M-004	20.9*56.9	0.649
HM-M-005	20.9*69.6	0.750
HM-M-006	20.9*56.8	0.880

### EXAMPLES OF LAYING

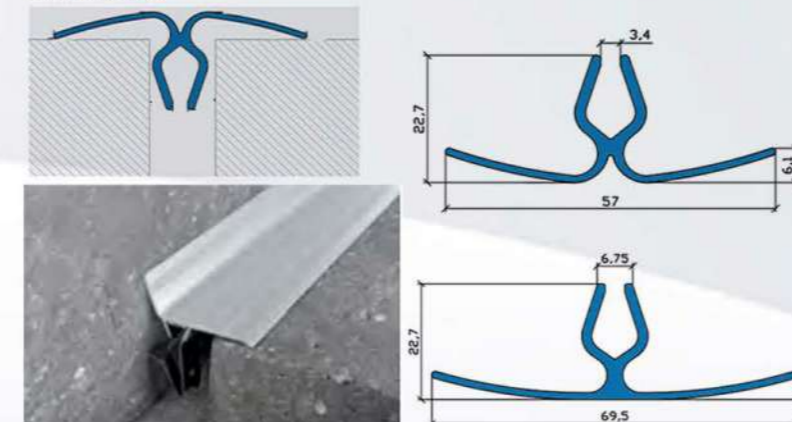

CODE	HIGHT/MM	WEIGHT KG/M
HM-M-002	22.7*57	0.405
HM-M-003	22.7*69.5	0.485

1. Choose the profile in the required width and material. 2. Insert the fixing clips into the relative groove, one every 50/75 cm (5 pcs. for wall applications - 10 pcs. for floor applications). 3. Insert/Lay the profile in the existing void, applying uniform pressure or using a plastic hammer, thereby creating a perfect joint cover. The same method is used for laying the corner profile.



84

# STAIR NOSING



## STAIR NOSING

STAIR NOSING for tile is a decorative material designed specifically for tile stairs, using high-quality materials and manufacturing techniques, with very high hardness and strength. Commonly used to protect the edges of stairs and prevent damage to the corners of ceramic tiles, it can effectively extend its service life. Applicable to all kinds of indoor ceramic stairs, such as residential, shops, hospitals, schools and other public places.

85

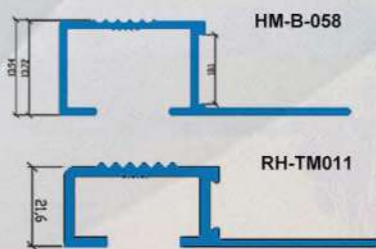

EXAMPLES AND INSTRUCTIONS FOR LAYING METHODS

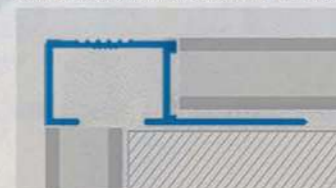

1. Choose the Stair nosing in the required width and colour according to the thickness of the tile (stairs).
2. First fix the riser part, placing it at the correct and final height.
3. Fill the empty spaces under the profile with the tile adhesive.
4. Apply the adhesive to the tread, lay the profile with the punched base fully sunk into the adhesive and align the profile so that its lip covers the edge of the riser tile.
5. Lay the tread tiles, aligning them so that they are flush with the upper and rear part of the profile and filling the internal part with adhesive. Oxidation marks in the polished/natural brass range may be easily removed with specific chemical products (Sidol-Smac).

CODE	H MM	KG/M
RH-TM011	9.6	0.218
HM-B-058	12.72	0.205

EXAMPLES AND INSTRUCTIONS FOR LAYING METHODS

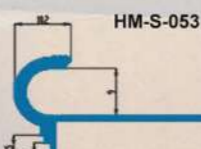
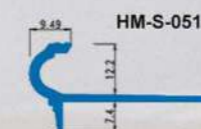

CODE	H MM	KG/M
HM-S-051	12.2	0.265
HM-S-053	11.3	0.223



# STAIR NOSING

EXAMPLES AND INSTRUCTIONS FOR LAYING METHODS

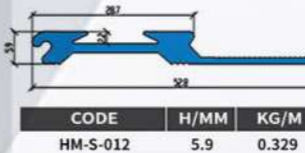
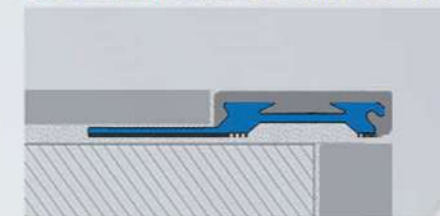

CODE	H/MM	KG/M
HM-S-012	5.9	0.329

1. Choose Stair nosing depending on the desired finish, light effect and polycarbonate plate.
2. If you are using the version with adhesive, clean first the surface where the profile will be installed. Once the surface has dried, remove the protective film and install the profile, applying adequate pressure on it.
3. If you are using the punched version, place the profile on the step tread and mark the position of the profile holes on the step tread.
4. Drill the step tread and fasten the profile using plugs.
5. Connect the Stair nosing to the low tension power supply and install the polycarbonate plate.



EXAMPLE AND INSTRUCTIONS FOR LAYING METHODS

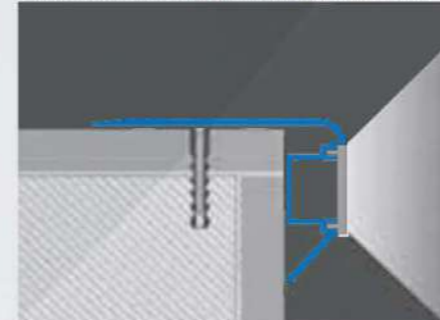

CODE	H MM	KG/M
HM-LED-A01	30	0.3



1. Choose Stair nosing LED depending on the desired finish, light effect and polycarbonate plate.
2. If you are using the version with adhesive, clean first the surface where the profile will be installed. Once the surface has dried, remove the protective film and install the profile, applying adequate pressure on it.
3. If you are using the punched version, place the profile on the step tread and mark the position of the profile holes on the step tread.
4. Drill the step tread and fasten the profile using plugs.
5. Connect the LED to the low tension power supply and install the polycarbonate plate.

EXAMPLE OF LAYING

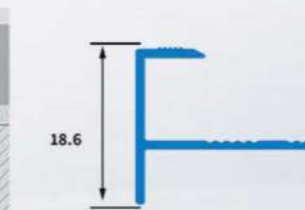

1. Choose the Stair nosing in the required width and colour according to the thickness of the tile (stairs).
2. First fix the riser part, placing it at the correct and final height.
3. Fill the empty spaces under the profile with the tile adhesive.
4. Apply the adhesive to the tread, lay the profile with the punched base fully sunk into the adhesive and align the profile so that its lip covers the edge of the riser tile.
5. Lay the tread tiles, aligning them so that they are flush with the upper and rear part of the profile and filling the internal part with adhesive.

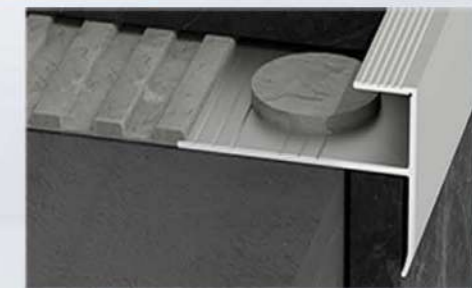

CODE	H MM	KG/M
HM-S-036	18.6	0.131

EXAMPLE OF LAYING

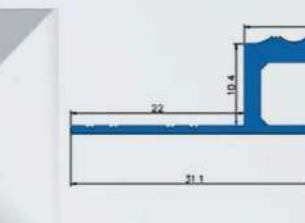

1. Choose Stair nosing LED depending on the desired finish, light effect and polycarbonate plate.
2. If you are using the version with adhesive, clean first the surface where the profile will be installed. Once the surface has dried, remove the protective film and install the profile, applying adequate pressure on it.
3. If you are using the punched version, place the profile on the step tread and mark the position of the profile holes on the step tread.
4. Drill the step tread and fasten the profile using plugs.
5. Connect the LED to the low tension power supply and install the polycarbonate plate.

CODE	H MM	KG/M
HM-LED-A04	23.3	0.39



86

# STAIR NOSING

## STAIR NOSING

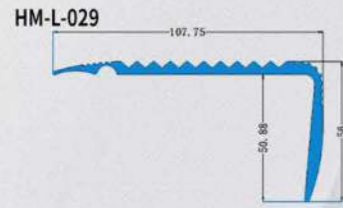

EXAMPLES AND INSTRUCTIONS FOR LAYING METHODS

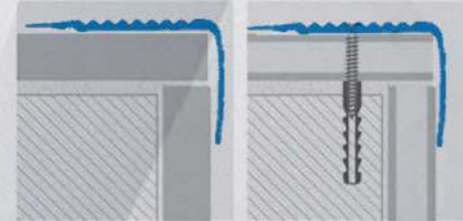

### Application

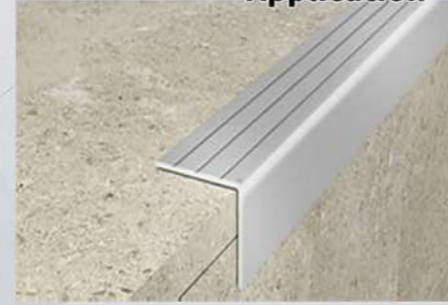

CODE	H MM	KG/M
HM-L-029	56	0.251
HM-L-150	20	0.168

**Adhesive version**  
 1. Choose the suitable profile and cut it to the necessary length. 2. Degrease, wash and clean the solid surface thoroughly. 3. Remove the protective paper from the adhesive. 4. Lay the profile by applying pressure evenly over the whole surface without using a hammer.

**Punched version**  
 1. Choose the suitable profile and cut it to the necessary length. 2. Mark the position of the holes using the existing holes in the profile as reference. 3. Insert the screw anchors into the drilled holes. 4. Fix the profile using flathead screws suitable for the relative slots in the profile.

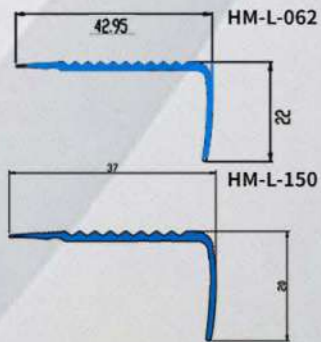
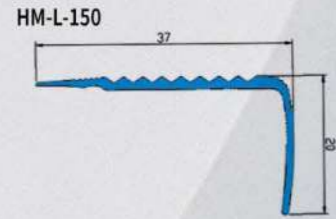

EXAMPLES AND INSTRUCTIONS FOR LAYING METHODS

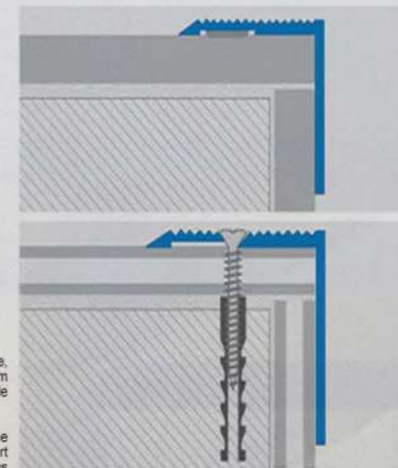

**Adhesive version**  
 1. Choose the suitable profile and cut it to the necessary length. 2. Degrease, wash and clean the solid surface thoroughly. 3. Remove the protective paper from the adhesive. 4. Lay the profile by applying pressure evenly over the whole surface without using a hammer.

**Punched version**  
 1. Choose the suitable profile and cut it to the necessary length. 2. Mark the position of the holes using the existing holes in the profile as reference. 3. Insert the screw anchors into the drilled holes. 4. Fix the profile using flathead screws suitable for the relative slots in the profile.

CODE	H MM	KG/M
HM-L-062	22	0.2
HM-L-150	20	0.168

EXAMPLES AND INSTRUCTIONS FOR LAYING METHODS

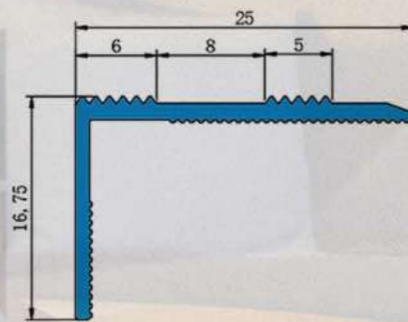
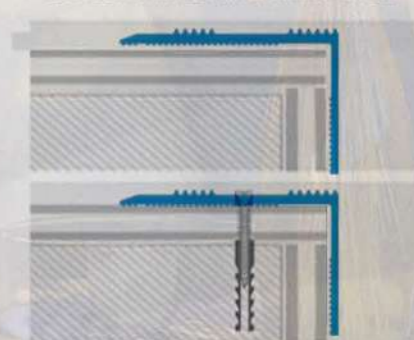

**Adhesive version**  
 1. Choose the suitable profile and cut it to the necessary length. 2. Degrease, wash and clean the solid surface thoroughly. 3. Remove the protective paper from the adhesive. 4. Lay the profile by applying pressure evenly over the whole surface without using a hammer.

**Punched version**  
 1. Choose the suitable profile and cut it to the necessary length. 2. Mark the position of the holes using the existing holes in the profile as reference. 3. Insert the screw anchors into the drilled holes. 4. Fix the profile using flathead screws suitable for the relative slots in the profile.

CODE	H MM	KG/M
HM-L-000	15	0.139

# STAIR NOSING



### Application

CODE	H MM	KG/M
HM-P-124	29	0.256
HM-P-125	20.5	0.261

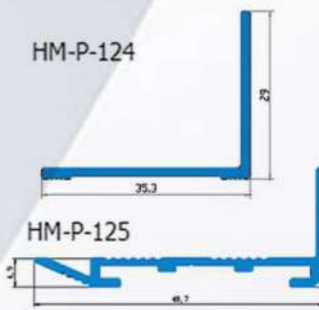

**Adhesive version**  
 1. Choose the suitable profile and cut it to the necessary length. 2. Degrease, wash and clean the solid surface thoroughly. 3. Remove the protective paper from the adhesive. 4. Lay the profile by applying pressure evenly over the whole surface without using a hammer.

**Punched version**  
 1. Choose the suitable profile and cut it to the necessary length. 2. Mark the position of the holes using the existing holes in the profile as reference. 3. Insert the screw anchors into the drilled holes. 4. Fix the profile using flathead screws suitable for the relative slots in the profile.

# STAIR NOSING

EXAMPLES AND INSTRUCTIONS FOR LAYING METHODS

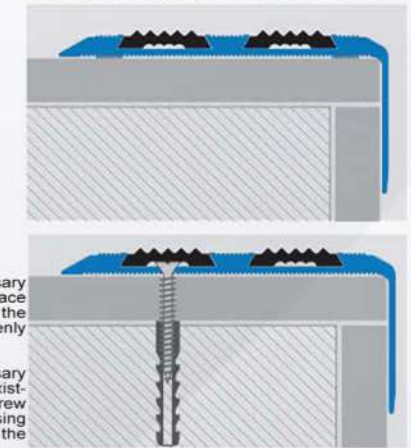

EXAMPLE AND INSTRUCTIONS FOR LAYING METHODS

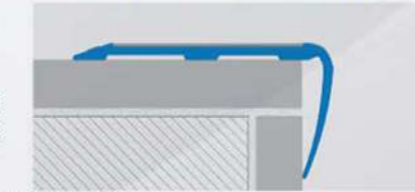

CODE	H x L mm
HM-S-002	32.5*70

**Adhesive version**  
 1. Choose the suitable profile and cut it to the necessary length. 2. Degrease, wash and clean the solid surface thoroughly. 3. Remove the protective paper from the adhesive. 4. Lay the profile by applying pressure evenly over the whole surface without using a hammer.

**Punched version**  
 1. Choose the suitable profile and cut it to the necessary length. 2. Mark the position of the holes using the existing holes in the profile as reference. 3. Insert the screw anchors into the drilled holes. 4. Fix the profile using flathead screws suitable for the relative slots in the profile.



CODE	H x L mm
HM-S-001	50*50
HM-S-002	50*50

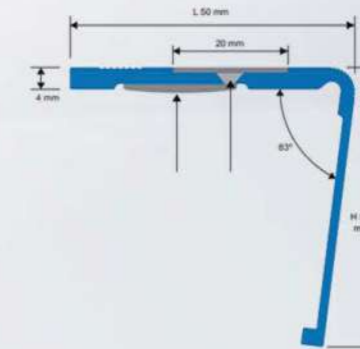

EXAMPLES FOR LAYING METHODS

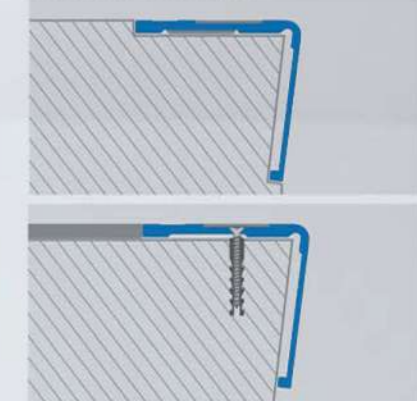

EXAMPLES AND INSTRUCTIONS FOR LAYING METHODS

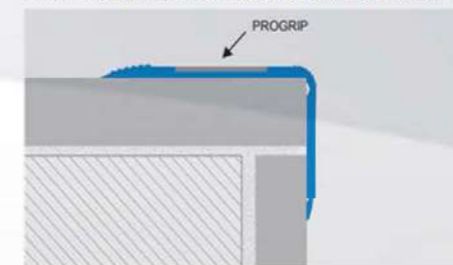

CODE	H MM	KG/M
HM-L-064	25	0.136

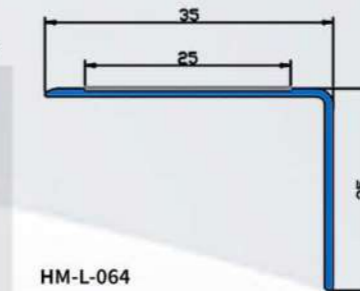

**Adhesive version**  
 1. Choose the suitable profile for covering the edge of the step. 2. Clean the surface on which the profile is to be laid, ensuring that it is grease-free and dry. Do not apply the strips at temperatures below 15°. 3. Remove the protective paper from the adhesive and lay correctly by applying pressure evenly over the whole profile without using a hammer. If the punched profile has been chosen, screw the profile to the step and apply the adhesive carborundum to hide the screws.





# STAIR NOSING

 HM-L-029 0.251kg/m	 HM-L-029-1 1.5kg/6m	 HM-L-062 0.2kg/m	 HM-L-150 0.168kg/m
 HM-L-191 0.386kg/m	 HM-L-198 0.187kg/m	 HM-L-199 0.252kg/m	 HM-L-295 0.158kg/m
 HM-L-296 0.194 kg/m	 Y-L-043 0.232kg/m	 HM-L-297-2 0.257kg/m	 Y-L-044 0.231 kg/m
 HM-L-298 0.331kg/m	 F-006 0.140 kg/m	 HM-L-299-2 0.411kg/m	 HM-L-324 0.31kg/m
 HM-L-331 0.078kg/m	 HM-L-346 0.083kg/m	 HM-L-364 0.063kg/m	 HM-L-366 0.324kg/m
 HM-L-030 1.4kg/6m	 HM-L-064 0.136kg/m	 HM-L-036 0.08kg/m	 HM-P-134 0.276kg/m

89

# STAIR NOSING

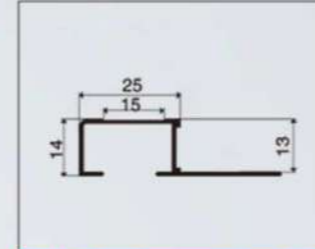
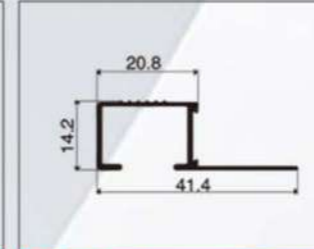
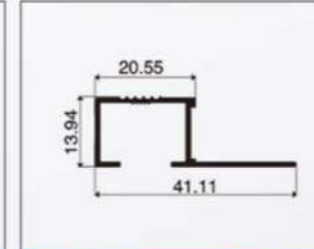
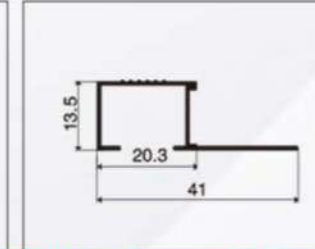
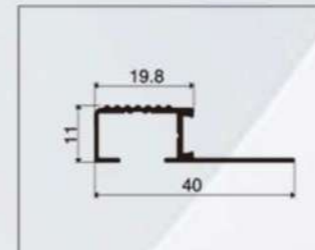
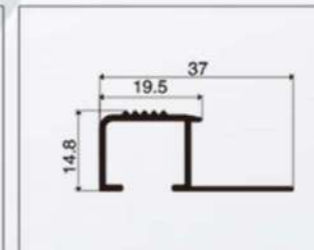
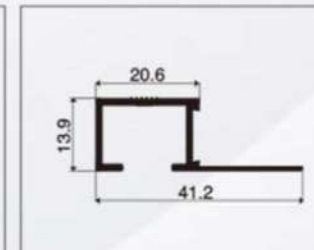
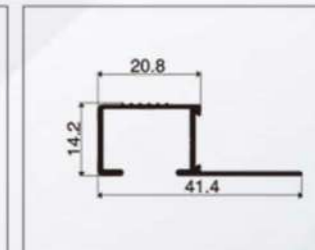
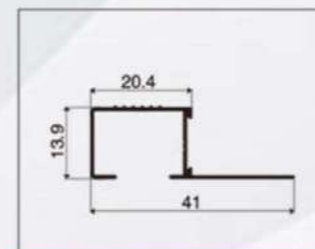
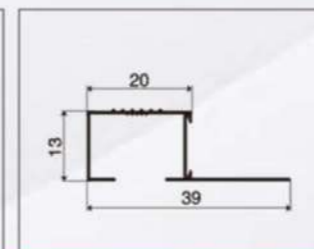
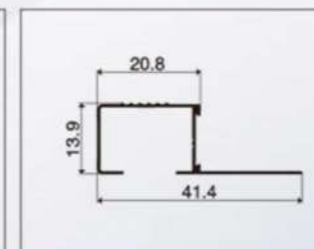
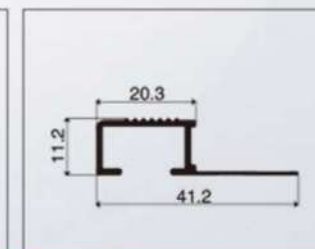
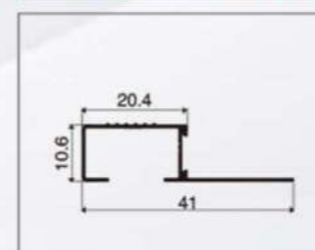
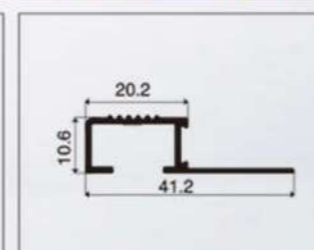
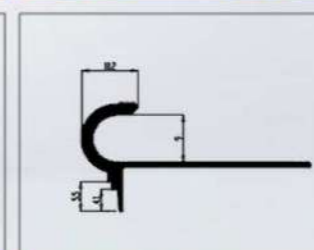
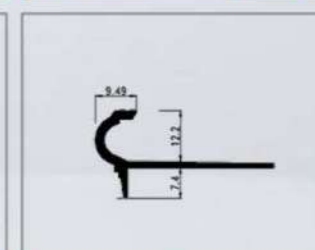
 HM-B-026 0.223kg/m	 HM-B-032 0.2kg/m	 HM-B-058 0.205kg/m	 HM-B-091 0.162kg/m
 HM-B-102 0.181kg/m	 HM-B-103 0.2kg/m	 HM-B-116 0.251kg/m	 HM-B-120 0.2kg/m
 HM-B-126 0.140kg/m	 HM-B-132 0.104kg/m	 HM-B-143 0.113kg/m	 HM-B-144 0.198kg/m
 HM-B-146 0.128kg/m	 HM-B-158 0.213kg/m	 HM-S-053 0.265KG/M	 HM-S-051 0.223KG/M

90

SKIRTING BOARD

# SKIRTING BOARD



# SKIRTING BOARD

**SKIRTING BOARD**, also known as a baseboard or mopboard, which is a protective and decorative molding installed along the base of an interior wall. Its advantages include concealing gaps, protecting walls from scuffs and adding a finishing touch to the room. Commonly used in residential and commercial spaces, skirting boards provide a polished look while serving a functional purpose.

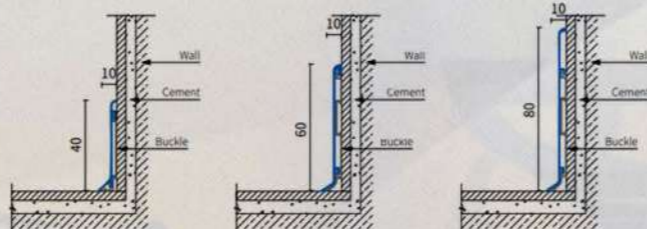

MODEL	SSZ-013	SSZ-011	SSZ-012
THICKNESS	1.1mm	1.1mm	1.1mm
HEIGHT	40mm	60mm	80mm

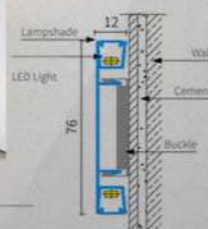
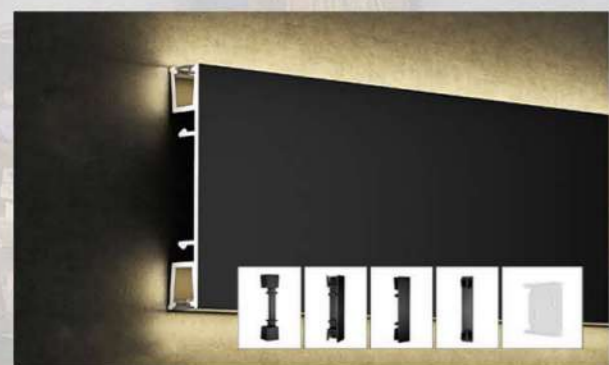

MODEL	JM-213
THICKNESS	1.0mm
HEIGHT	76mm

SKIRTING BOARD

INSTALLATION STEPS

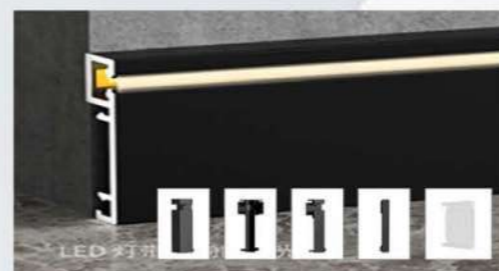
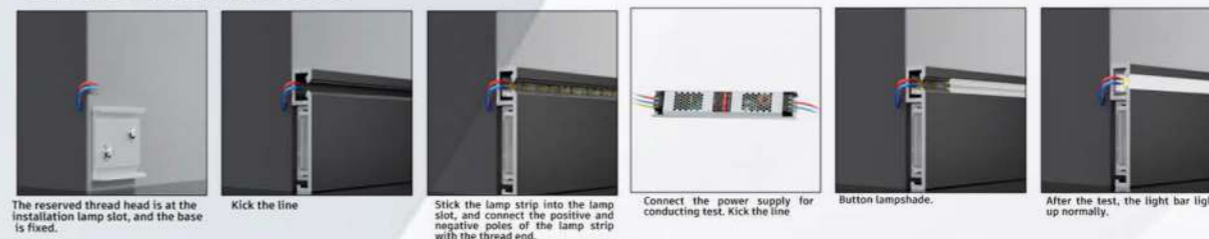

MODEL	JM-178
THICKNESS	1.0mm
HEIGHT	50mm 78mm

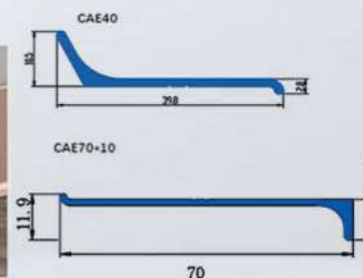
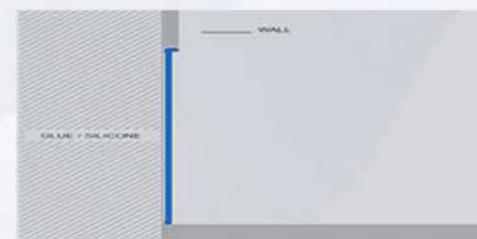
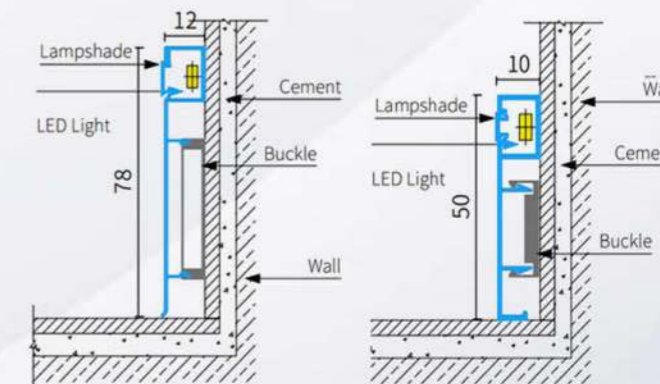

1. Fix the skirting board using glue/silicone (exposed side) before making the required coat, calculating all the heights and distances. 2. Carry out the surface finishing aligning the lower part flush to the skirting board. Pay attention to the external edges of the aluminum "skirting board". They must be protected against agents such as adhesives and sealants and against grinding or scraping actions.

CODE	H MM	KG/M
CAE40	39.8	0.190
CAE60	60	0.298
CAE80	80	0.385
CAE100	100	0.472
CAE70	70	0.341

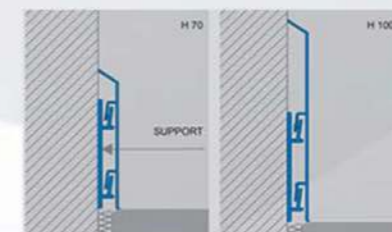
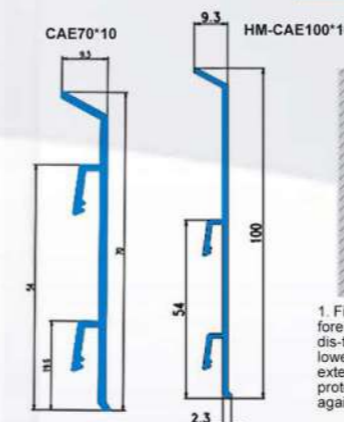
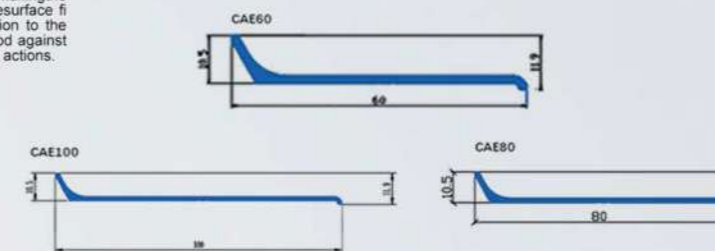

1. Fix the skirting board using glue/silicone (exposed side) before making the required coat, calculating all the heights and distances. 2. Carry out the surface finishing aligning the lower part flush to the skirting board. Pay attention to the external edges of the aluminum "skirting board". They must be protected against agents such as adhesives and sealants and against grinding or scraping actions.



CODE	H MM	KG/M
CAE70*10	70*10	0.361
HM-CAE100*10	100*10	0.465

SKIRTING BOARD

# SKIRTING BOARD

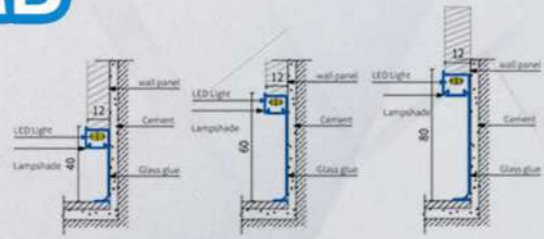

MODEL	JD2021-20	JD2021-21	JD2021-22
THICKNESS	1.0mm		
HEIGHT	40mm/60mm/80mm		

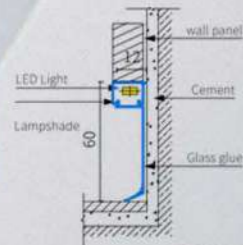

MODEL	JD2021-20
THICKNESS	1.0mm
HEIGHT	60mm

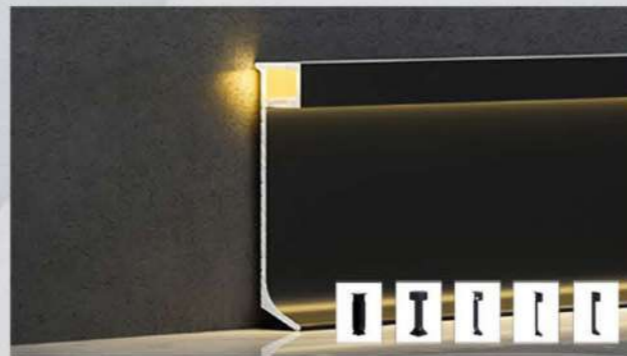

93

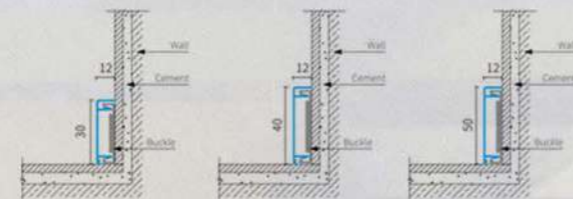
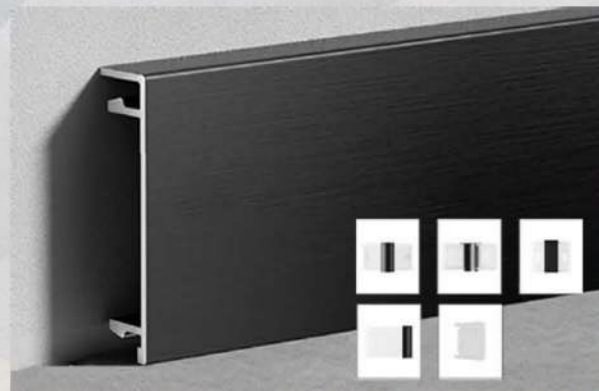

JM0003	JM0004	JM001-5
1.0mm	0.8mm	0.6mm/0.8mm/1.0mm
30mm	40mm	50mm

SKIRTING BOARD

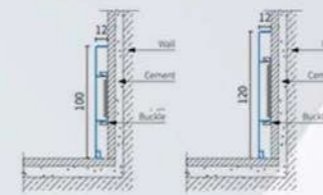
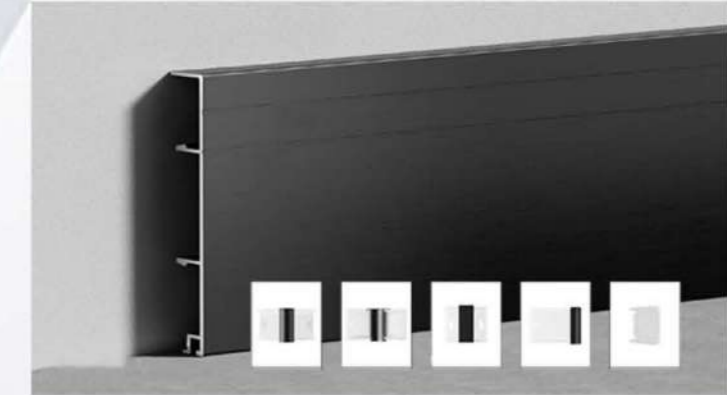

MODEL	JM010-10
THICKNESS	1.0mm
HEIGHT	100mm/120mm

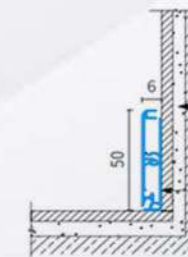

MODEL	SL-1409
THICKNESS	1.3mm
HEIGHT	50mm

94

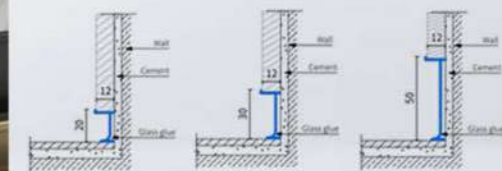

MODEL	SSZ-010	SSZ-011	SSZ-012
THICKNESS	1.3mm	1.3mm	1.3mm
HEIGHT	20mm	30mm	50mm

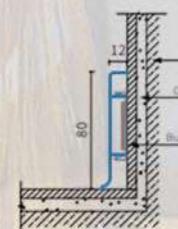

MODEL	SL-1409
THICKNESS	1.0mm
HEIGHT	80mm

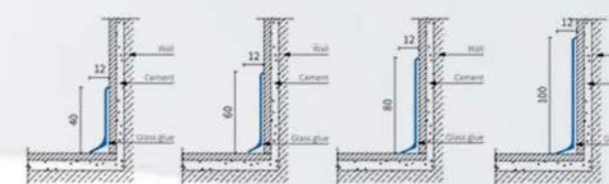

MODEL	SSZ-013	SSZ-011	SSZ-012
THICKNESS	0.8/1.2mm	0.8/1.2mm	0.8/1.2mm
HEIGHT	40mm	60mm	80mm



# SKIRTING BOARD

**T293 LED SKIRTING BOARD**

ID	T293
Unit: mm	
SCALE	2.5m/branch
COLOUR	Pearl black



Pearl Black

### ACCESSORIES DISPLAY



Internal angle External angle Left end cup Right end cup

95

**CBF DOUBLE RAIL SKIRTING BOARD**

ID	CBF60
GRAPHICAL REPRESENTATION	
SCALE	2.5m/piece
COLOUR	Soft light white, primrose gold, starry sky grey, millet grey, pearl black



Soft Light White Primrose Gold Astral Grey



Millet grey Pearl black Soft silicone cover

### ACCESSORIES DISPLAY



Internal angle External angle Left end cup Straight connector Right end cup

# SKIRTING BOARD

**CBE DOUBLE RAIL SKIRTING BOARD**

ID	CBE40	CBE60	CBE80
Unit: mm	4.4	4.51	4.8
GRAPHICAL REPRESENTATION			
COLOUR	2 m/branch		
	Pearl white	cement grey	Raphael tea
CBE40	✓	✓	✓
CBE60	✓	✓	✓
CBE80	✓	✓	✓
	starry sky grey	Millet grey	Pearl black
CBE40	✓	✓	✓
CBE60	✓	✓	✓
CBE80	✓	✓	✓
	Soft white	Moon light	cocoa cheese
CBE40	✓	✓	✓
CBE60	✓	✓	✓
CBE80	✓	✓	✓
	brass gold	rose gold	ivory
CBE40	✓	✓	✓
CBE60	✓	✓	✓
CBE80	✓	✓	✓
	apricot grey		
CBE40	✓	✓	✓
CBE60	✓	✓	✓
CBE80	✓	✓	✓



Moon grey Raphael tea Rose gold (brushed) Bronzing gold (brushed)

**CBE DOUBLE RAIL SKIRTING BOARD**

ID	CBE25	CBE50
Unit: mm	4.5	4.5
GRAPHICAL REPRESENTATION		
COLOUR	2 m/branch	
	Pearl black	Sky grey
25	✓	✓
50	✓	✓
	Pearl white	Apricot grey
25	✓	✓
50	✓	✓

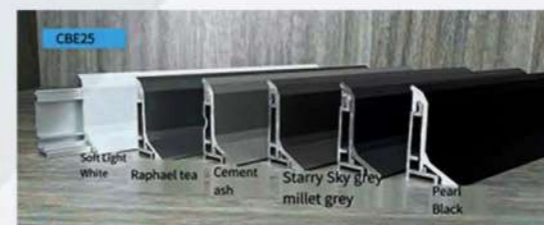

Auroral grey Cement ash Raphael tea

**CBE DOUBLE RAIL SKIRTING BOARD**

ID	CBE25	CBE50
Unit: mm	4.5	4.5
GRAPHICAL REPRESENTATION		
COLOUR	2 m/branch	
	Pearl black	Sky grey
25	✓	✓
50	✓	✓
	Pearl white	Apricot grey
25	✓	✓
50	✓	✓



Pearl black

### COLOR DISPLAY



Cement ash Sky grey Millet grey Phantom black

96

**BB3 HEAVY DUTY SKIRTING BOARD**

ID	BB340	BB350	BB360	BB380
Unit: mm				4.5
GRAPHICAL REPRESENTATION				
SCALE	2.5 M			
COLOUR	Raphael tea, cement grey, starry sky grey, millet grey, phantom black, Pearl white (no BB380), Ivory white (no BB380), apricot grey (no BB380)			

SKIRTING BOARD

# SKIRTING BOARD

TVB MICRO SKIRTING BOARD																						
ID	TVB40																					
Unit: mm																						
SCALE	2.5m/branch																					
COLOR	<table border="1"> <tr> <td>Ivory white</td> <td>Primrose Gold</td> <td>Matte Champagne</td> <td>Star grey</td> <td>Millet grey</td> <td>Pearl black</td> <td>Phantom black</td> </tr> <tr> <td>TVB40</td> <td>✓</td> <td>✓</td> <td>✓</td> <td>✓</td> <td>✓</td> <td>✓</td> </tr> <tr> <td>TVB50</td> <td>✓</td> <td></td> <td></td> <td></td> <td></td> <td>✓</td> </tr> </table>	Ivory white	Primrose Gold	Matte Champagne	Star grey	Millet grey	Pearl black	Phantom black	TVB40	✓	✓	✓	✓	✓	✓	TVB50	✓					✓
Ivory white	Primrose Gold	Matte Champagne	Star grey	Millet grey	Pearl black	Phantom black																
TVB40	✓	✓	✓	✓	✓	✓																
TVB50	✓					✓																

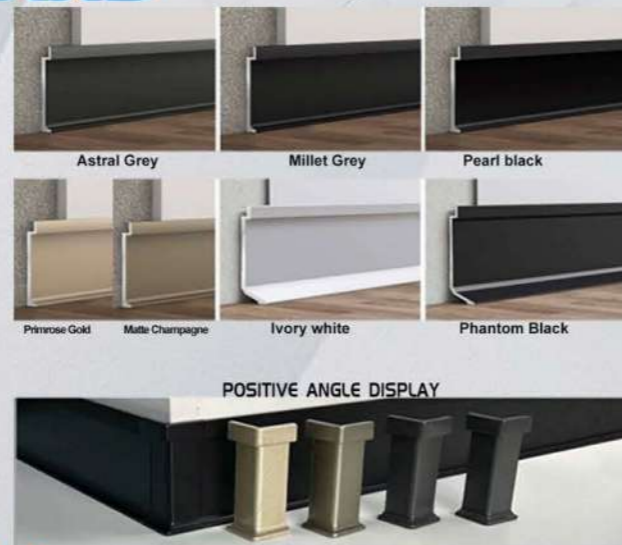

CCE SILICONE LAMP/MINIMALIST SKIRTING BOARD			
ID	CCE 815	CCE 826	CCE 1050
Unit: mm			
SCALE	2.5 m/branch		
COLOR	Starry sky gray, pearl black		Aurora gray, starry sky gray, pearl black

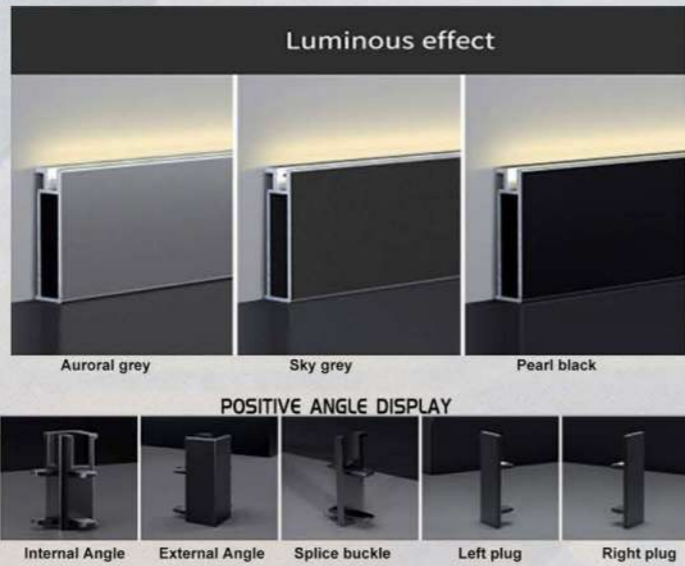

TVB MICRO EMBEDDED SKIRTING BOARD																						
ID	TVB 40																					
Unit: mm																						
SCALE	2.5m/branch																					
COLOR	<table border="1"> <tr> <td>Ivory white</td> <td>Primrose Gold</td> <td>Matte Champagne</td> <td>Star grey</td> <td>Millet grey</td> <td>Pearl black</td> <td>Phantom black</td> </tr> <tr> <td>TVB40</td> <td>✓</td> <td>✓</td> <td>✓</td> <td>✓</td> <td>✓</td> <td>✓</td> </tr> <tr> <td>TVB50</td> <td>✓</td> <td></td> <td></td> <td></td> <td></td> <td>✓</td> </tr> </table>	Ivory white	Primrose Gold	Matte Champagne	Star grey	Millet grey	Pearl black	Phantom black	TVB40	✓	✓	✓	✓	✓	✓	TVB50	✓					✓
Ivory white	Primrose Gold	Matte Champagne	Star grey	Millet grey	Pearl black	Phantom black																
TVB40	✓	✓	✓	✓	✓	✓																
TVB50	✓					✓																

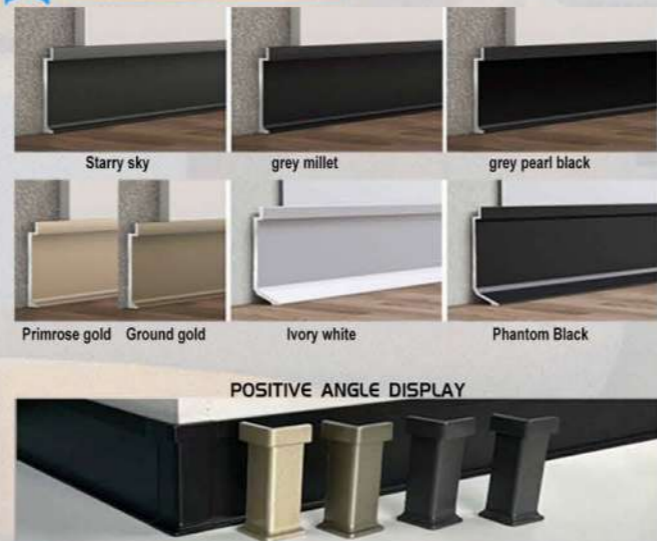

SKIRTING BOARD

TH30G SKIRTING BOARD	
ID	TH30G(glow/no lights)
Unit: mm	
SCALE	2.5m/branch
COLOR	Matte gold, Matte Champagne, Matte black



97

98



TERRACE AND BALCONY DRAIN DRIP

# TERRACE AND BALCONY DRAIN DRIP



## TERRACE AND BALCONY DRAIN DRIP

TERRACE AND BALCONY DRAIN DRIP is a specialized trim designed for outdoor spaces, providing an elegant border around terrace edges. Its advantages include enhanced safety, durability against weather elements and a polished appearance. Ideal for residential and commercial terraces, balconies and patios, terrace profiles not only serve a protective function but also contribute to a visually appealing and well-finished outdoor environment.

99

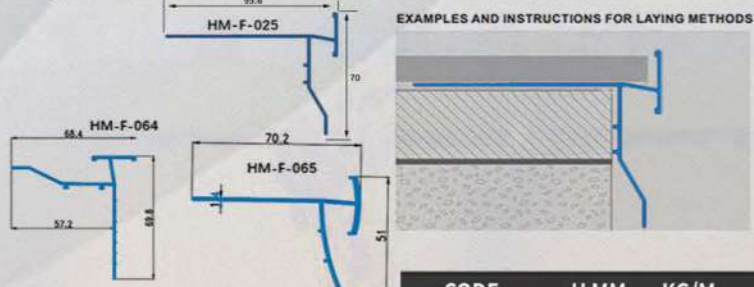

1. Choose the PROTERRACE DRAIN FDP in accordance to the thickness of the tile and of the desired finishing; 2. Fix the pre-welded outside corners to the screed; 3. Cut the PROTERRACE DRAIN FDP at desired length; lay the profile, joining it to the corners using the linking element and fastening it with screws to the substrate; 4. Apply the desired waterproofing system, sealing the profile to the joint; 5. Lay the tiles, leaving at least about 5 millimeters between the tile and the profile; 6. Fill the space between the tiles and the profile with a plaster suitable for the chosen floor covering.

CODE	H MM	KG/M
HM-F-025	92.6	0.802
HM-F-064		0.575
HM-F-066	Angle code	0.473
HM-F-065		0.572
HM-F-067	Angle code	0.429

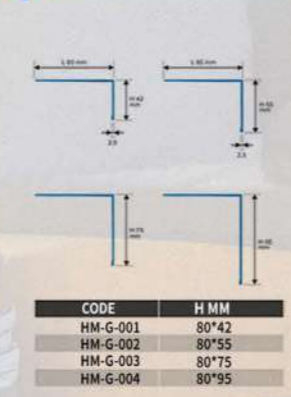
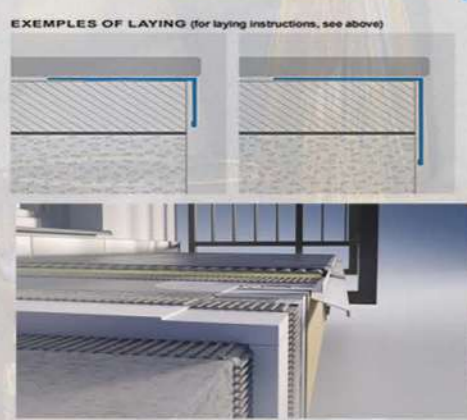
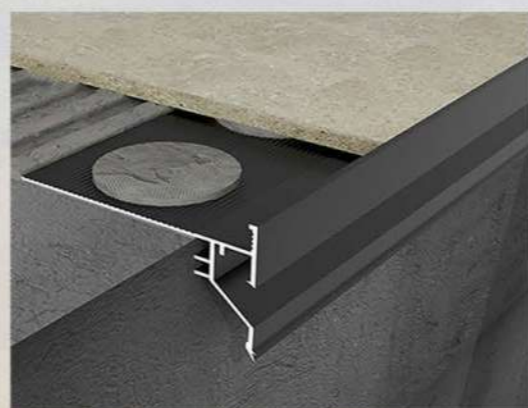

CODE	H MM
HM-G-001	80*42
HM-G-002	80*55
HM-G-003	80*75
HM-G-004	80*95



# TERRACE AND BALCONY DRAIN DRIP

TERRACE AND BALCONY DRAIN DRIP

EXAMPLES AND INSTRUCTIONS FOR LAYING METHODS

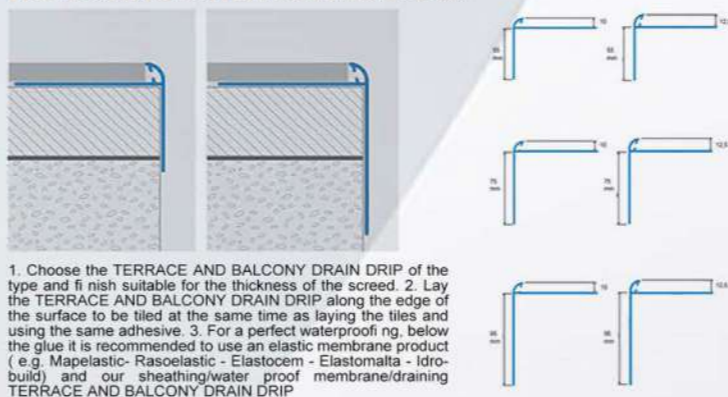

1. Choose the TERRACE AND BALCONY DRAIN DRIP of the type and finish suitable for the thickness of the screed. 2. Lay the TERRACE AND BALCONY DRAIN DRIP along the edge of the surface to be tiled at the same time as laying the tiles and using the same adhesive. 3. For a perfect waterproofing, below the glue it is recommended to use an elastic membrane product (e.g. Mapelastoc - Rasoeelastic - Elastocem - Elastomalta - Idrobuild) and our sheathing/waterproof membrane/drainage TERRACE AND BALCONY DRAIN DRIP.



CODE	h x H x L mm
HM-Q-001	10 x 55 x 80
HM-Q-002	10 x 75 x 80
HM-Q-003	10 x 95 x 80
HM-Q-004	12,5 x 55 x 80
HM-Q-005	12,5 x 75 x 80
HM-Q-006	12,5 x 95 x 80

EXAMPLES AND INSTRUCTIONS FOR LAYING METHODS

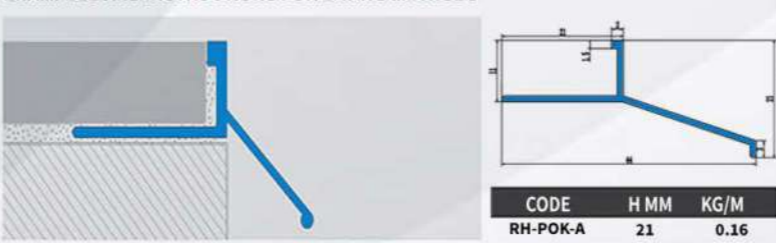

1. Choose the profile with the required height. 2. Lay the BALCONY DRAIN DRIP along the edge of the surface to be tiled at the same time as laying the tiles and using the same adhesive. 3. For a perfect waterproofing, below the glue it is recommended to use an elastic membrane product (e.g. Mapelastoc - Rasoeelastic - Elastocem - Elastomalta - Idrobuild) and our sheathing/waterproof membrane/drainage BALCONY DRAIN DRIP.

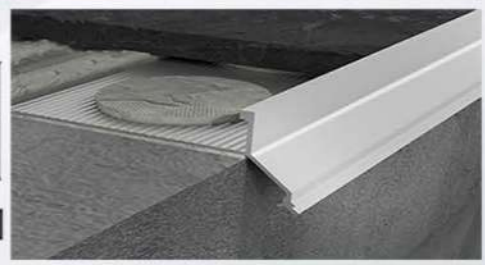

CODE	H MM	KG/M
RH-POK-A	21	0.16

100

# ACCESSORIES

OUTSIDE CORNER 90°



INSIDE CORNER 90°



OUTSIDE CORNER 90°

INSIDE CORNER 90°

INSIDE CORNER 180°

INSIDE CORNER 135°

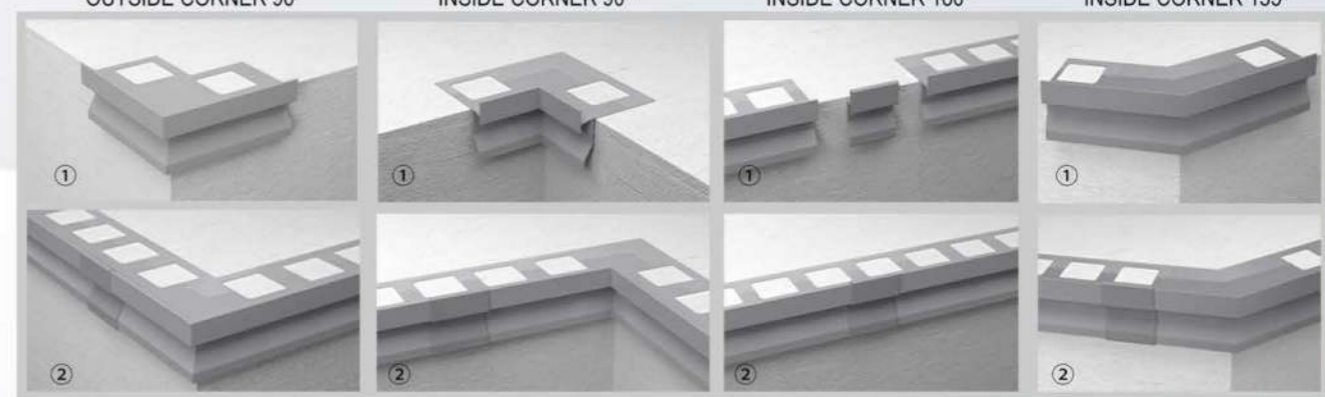

LED PROFILE

# LED PROFILE



101

LED PROFILE, is a specialized channel designed to house and diffuse LED strips, combining functional lighting with aesthetic appeal. Its advantages include enhanced illumination, flexibility and a sleek appearance. Ideal for architectural lighting, interior design accents and ambient lighting in residential and commercial spaces, LED profiles offer a versatile solution to illuminate spaces while maintaining a modern and refined look.











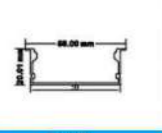



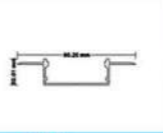
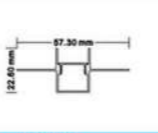

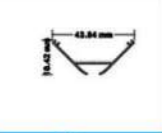
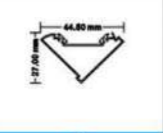
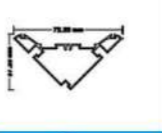
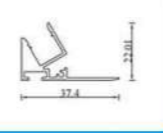
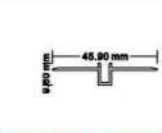
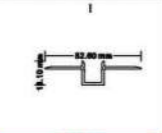

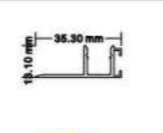
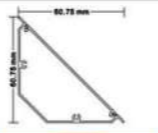
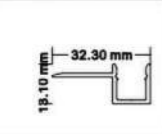
 5.00 mm CSOK9	 6.10 mm CSOK10	 6.60 mm CSOK11	 11.20 mm CSOK13	 12.30 mm CSOK14	 15.2 mm CSOK16
 10.60 mm CSOK3	 16 mm CSOK19	 16.7 mm CSOK20	 19.85 mm CSOK21	 19.00 mm CSOK22	 22.70 mm CSOK23
 8.60 mm CS21	 8.70 mm CS2029	 15.30 mm CS265	 11.60 mm CSOK24	 14.00 mm CSOK34	 14.40 mm CS96
 11.00 mm CS2102	 23.80 mm CS56	 14.90 mm CS3178	 4.30 mm 46	 4.00 mm CS2018	 5.00 mm CS2016

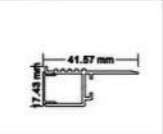

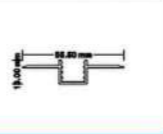
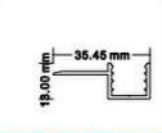

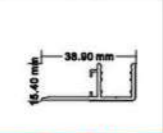
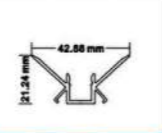
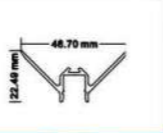

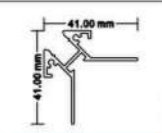
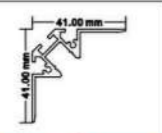
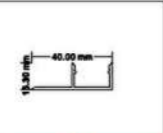
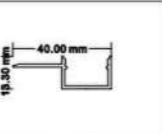
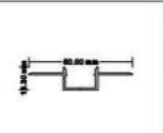
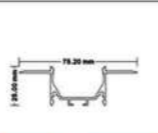
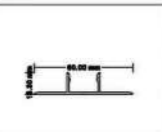
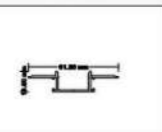
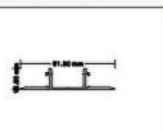
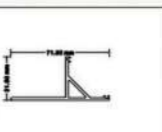
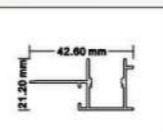
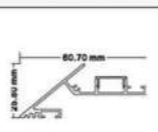
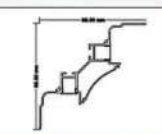
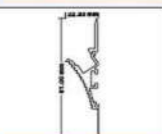
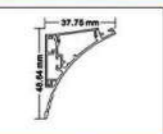
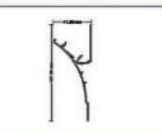
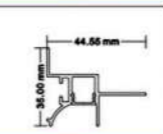
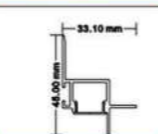
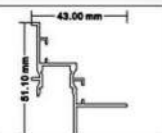
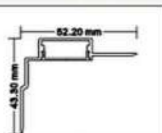
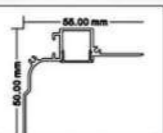

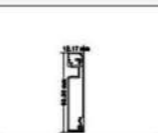
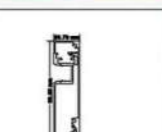
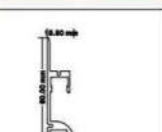
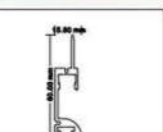
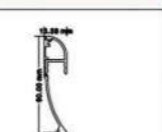
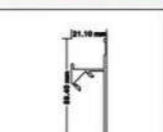
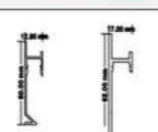





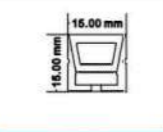

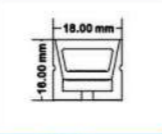
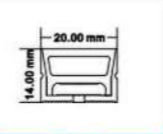

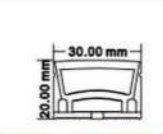
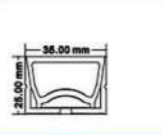







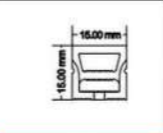
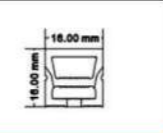
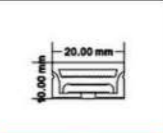
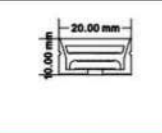
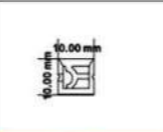

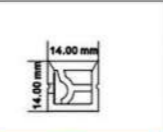
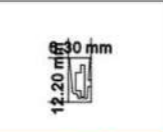
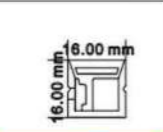
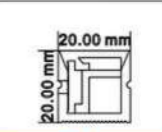
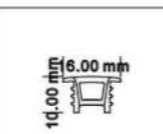
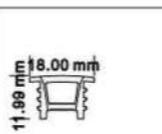

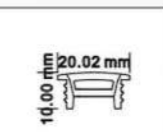
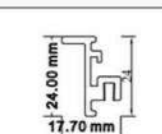
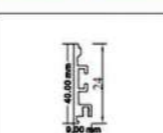
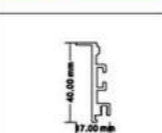

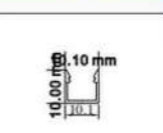
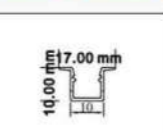
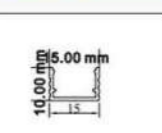
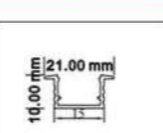
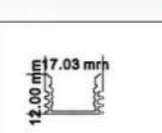
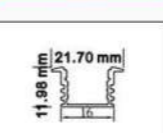
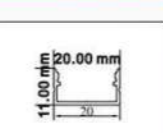
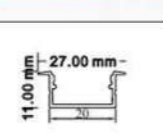
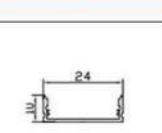
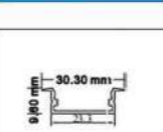
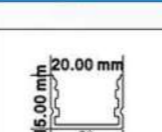
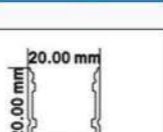
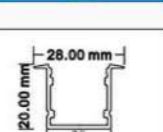
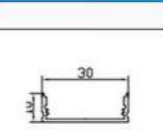
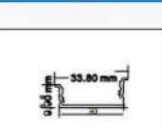
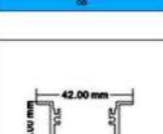
 12.20 mm CS117A	 40.00 mm CS117	 30.00 mm CS316A	 40.00 mm CS316	 70 mm CS321	 22.20 mm CS2029
 12.20 mm CS222	 10.00 mm CS324	 17.00 mm CS324A	 15.00 mm CS198	 17.00 mm CS1980	 22.00 mm CS311
 17.30 mm CS72	 9.10 mm YH-30	 4.30 mm CS45	 4.00 mm CS2018	 5.00 mm CS2016	 18.50 mm CS2015
 5.00 mm CS80	 12.00 mm CS81	 4.50 mm 197	 20.60 mm CS325	 5.80 mm 300	 21.60 mm 340
 17.00 mm 11	 24.70 mm 128	 6.60 mm CS122	 24.70 mm CS121	 17.50 mm CS120	 17.00 mm 29
 24.40 mm 146	 17.03 mm CS131	 21.70 mm CS131A	 5.10 mm CS298	 17.20 mm 57	 24.50 mm 193
 24.50 mm CS119	 17.10 mm CS2007	 20.00 mm CS211	 27.00 mm CS211A	 20.00 mm CS37	 19.30 mm CS219
 5.00 mm CS267	 28.00 mm CS75	 20.00 mm CS36	 23.30 mm 26	 30.30 mm 68	 23.60 mm CS38
 30.00 mm CS39	 27.30 mm CS190	 27.30 mm CS348A	 22.60 mm CS191	 36.01 mm CS190	 27.00 mm CS314
 25.51 mm CS134	 35.00 mm CS134A	 33.80 mm CS2010	 38.00 mm CS100	 30.00 mm 236	 30.60 mm CS75
 43.00 mm 235	 43.00 mm CS77	 38 mm CS347A	 35.76 mm CS298	 60.30 mm CS298A	 16.10 mm CS298B

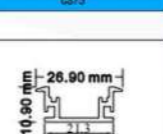
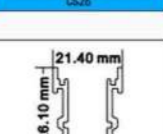
102

LED PROFILE

# LED PROFILE

 CS3020	 CS58	 CS2K22	 58	 CS10	 CS290A
 CS59A	 CS61	 CS	 CS	 CS2077#	
 CS 318	 CS 01#	 CS 02	 CS 03	 CS 172	 CS 45*45
 CS 12	 CS 205	 CS 327A#	 CS 327#	 CS 45*45	
 CS 327B	 CS 327C	 CS 261#	 CS 05	 CS 04	 CS 45*45
 2054	 2053	 326B	 326C	 326	 CS 09
 326A	 36	 07	 344#	 290	 CS-350
 CS251#	 CS256	 CS255	 CS250#	 CS305	 CS2
 CS234A	 CS3	 CS8	 CS20#	 CS20#	 CS20#
 CS20#	 CS20#	 CS20#	 CS20#	 CS20#	 CS20#

 8*8	 10*10	 12*12	 14*14	 15*15	 15*10
 16*16	 18*16	 20*14	 20*20	 30*20	 25*25
 30*20	 30*11	 30*14	 40*25	 40*25.5	 50*25.5
 10*10	 12*12	 15*15	 16*16	 20*10	 20*10
 10*10	 12*12	 14*14	 12*20	 16*16	 20*20
 10*10	 12*12	 14*14	 12*20	 16*16	 20*20
 10*10	 12*12	 14*14	 10*10	 10*10	 CS20
 CS40	 CS40	 CS75	 CS84	 CS95	 CS80
 CS81	 CS131	 CS131A	 CS2037	 CS2036	 26
 16	 CS37	 CS34	 CS79	 CS26	 CS1010
 CS40A	 736	 215	 CS20	 CS10	 CS346



## ALUMINUM PROFILE

# CORNER

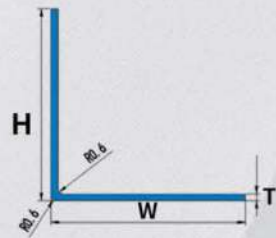

CODE	H*W/MM	WEIGHT KG/M
HM-K-090	6*11	0.043
HM-K-033	10*10	0.047
HM-K-004	11*11	0.057
HM-K-034	15*15	0.071
HM-K-036	10*20	0.071
HM-K-037	11*16	0.071
HM-K-005	16*16	0.084
HM-K-029	20*20	0.096
HM-K-062	15*30	0.107

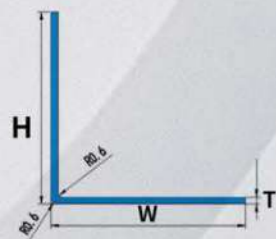

CODE	H*W*T/MM	WEIGHT KG/M	CODE	H*W*T/MM	WEIGHT KG/M
HM-K-009	11.5*19.5	0.120	HM-K-089	17*30	0.244
HM-K-106	15.5*15.5	0.120	HM-K-074	35*35	0.260
HM-K-030	25*25*0.9	0.120	HM-K-097	20*35	0.288
HM-K-044	9.5*19.5*1.5	0.122	HM-K-021	17*40	0.299
HM-K-107	17.5*17.5*1.5	0.136	HM-K-019	30*30	0.316
HM-K-035	30*30*0.9	0.145	HM-K-046	20*52	0.380
HM-K-073	20*30	0.146	HM-K-020	40*40	0.424
HM-K-006	19.5*19.5*1.5	0.153	HM-K-043	40*40	0.428
HM-K-045	16.5*23.5*1.5	0.156	HM-K-022	30*52	0.435

105

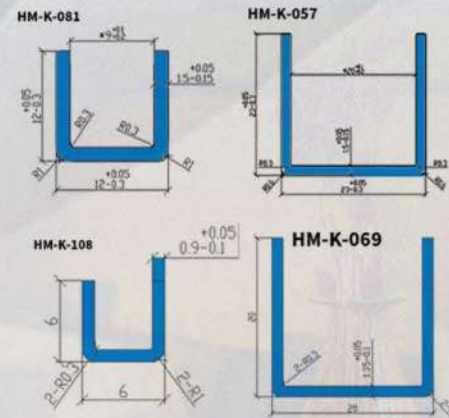

CODE	H*W*T/MM	WEIGHT KG/M
HM-K-067	6*6*0.9	0.039
HM-K-081	6*6	0.043
HM-K-070	8*8*0.9	0.053
HM-K-017	8*8	0.060
HM-K-057	10*10	0.068
HM-K-013	10*10*1	0.076
HM-K-078	10*15*0.9	0.080
HM-K-108	10*15	0.129
HM-K-014	10*15*1.5	0.130
HM-K-049	12*12	0.134
HM-K-068	15*19	0.169
HM-K-069	20*20*1.35	0.209
HM-K-077	18*20*1.1	0.211
HM-K-082	23*23	0.269

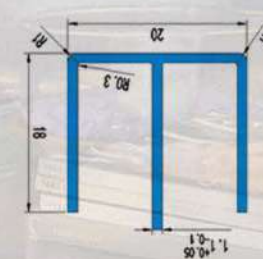
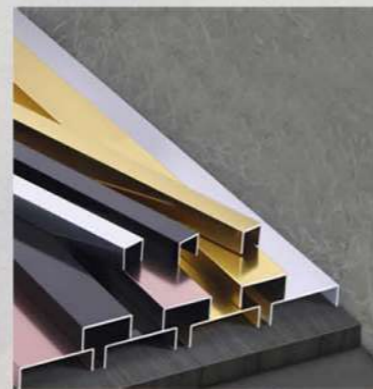

CODE	H*W*T/MM	WEIGHT KG/M
HM-K-083	19*19*1.5	0.220

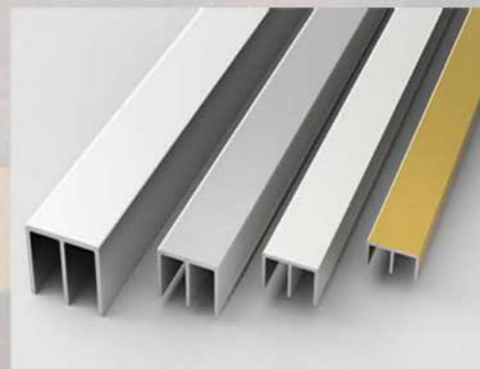

## ALUMINUM PROFILE

# FLAT

HM-K-002

HM-K-076

HM-K-001

HM-K-050

HM-K-099

HM-K-054

HM-K-018

HM-K-092

HM-K-075

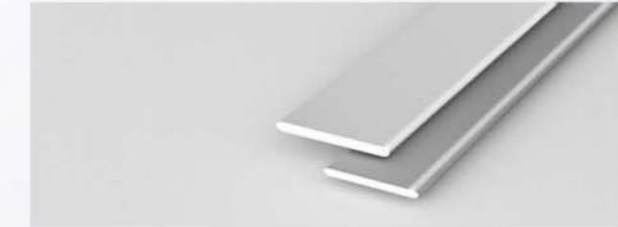
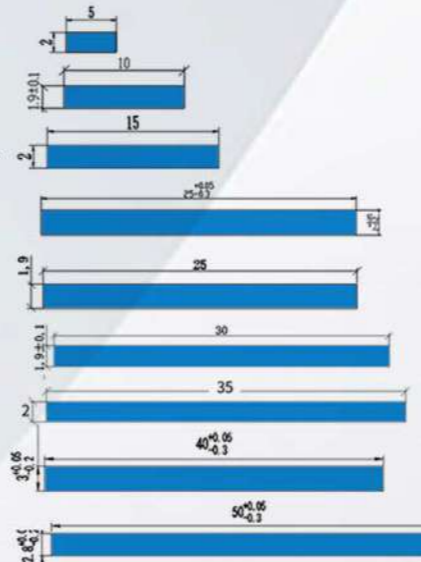

CODE	HIGHT/MM	WEIGHT KG/M
HM-K-002	5*2	0.027
HM-K-001	15*2	0.052
HM-K-076	10*1.9	0.052
HM-K-050	25*2	0.129
HM-K-099	25*2	0.136
HM-K-054	30*1.9	0.155
HM-K-018	35*2	0.19
HM-K-092	40*3	0.326
HM-K-075	50*2.8	0.381

# ROUND TUBE

HM-K-041

HM-K-042

HM-K-098

HM-R-029

HM-R-050

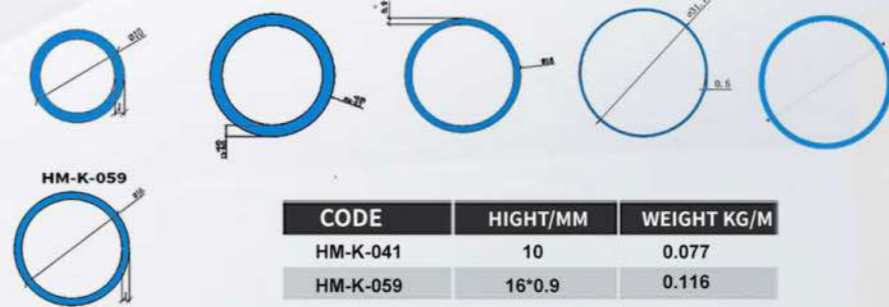

CODE	HIGHT/MM	WEIGHT KG/M
HM-K-041	10	0.077
HM-K-059	16*0.9	0.116
HM-K-042	16	0.128
HM-K-098	16	0.186
HM-K-029	31.7	0.133

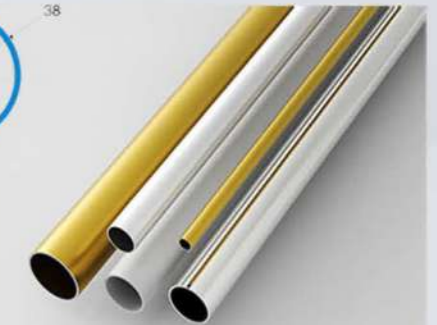

106

# FULL ROUND TUBE

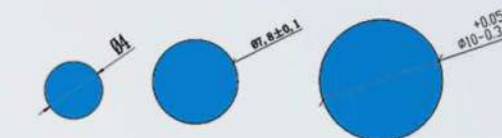

CODE	HIGHT/MM	WEIGHT KG/M
HM-K-003	4	0.034
HM-K-060	7.8	0.130
HM-K-091	10	0.214

ALUMINUM PROFILE

# EMPTY SQUARE TUBE

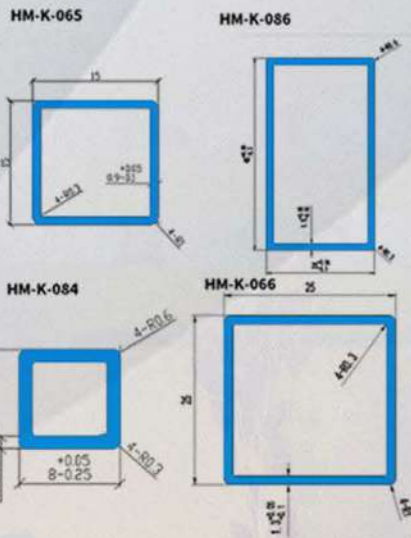

CODE	H*W*T/MM	WEIGHT KG/M
HM-K-084	8*8	0.076
HM-K-010	10*10	0.097
HM-K-105	10*12	0.107
HM-K-065	15*15	0.136
HM-K-085	16*16	0.236
HM-K-066	25*25	0.333
HM-K-100	24*24	0.367
HM-K-086	45*25	0.546



L x H mm
8 x 8
10 x 10



107

ALUMINUM PROFILE



CODE	H*W*T/MM	WEIGHT KG/M
HM-K-058	7.2*18	0.077

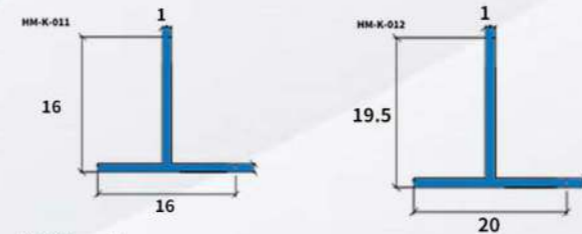
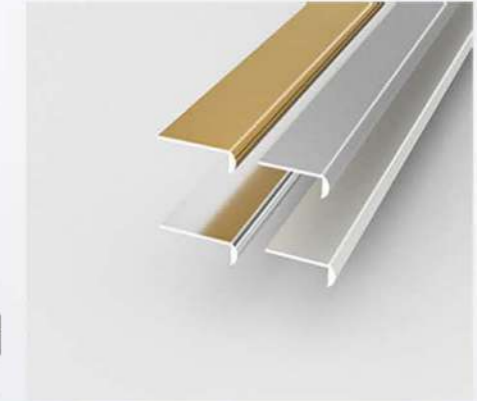

CODE	H*W*T/MM	WEIGHT KG/M
HM-K-011	16*16	0.084
HM-K-012	19.5*20	0.155
HM-K-061	15*15*1.4	0.109



108

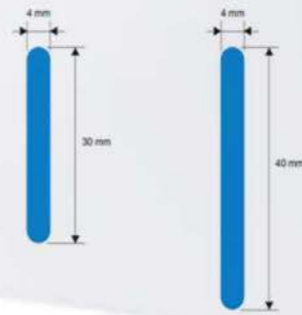

L mm
30
40

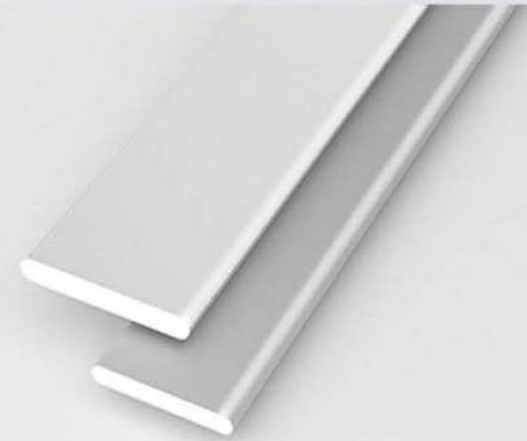



SEAHAWK BUILDING MATERIALS Co.,Ltd.  
[www.seahawkdeco.com](http://www.seahawkdeco.com)  
Phone:+86 189 0280 0979  
WhatsApp:+63 945 435 0435  
[info@seahawk-bm.com](mailto:info@seahawk-bm.com)

